

# Transmission Line Availability Data Guidelines and Definitions

Edited by:

<p>Gregg A. Spindler SGS Statistical Services 3975 Pompey Hollow Road Cazenovia, NY 13035 (315) 655-8187 gregg.spindler@sgsstat.com <a href="http://www.sgsstat.com">www.sgsstat.com</a></p>	<p>Edward A. Kram, P.E. Blue Arc Energy Solutions, Inc 106 W Calendar Court #250 LaGrange, IL 60525 (708) 354 2710 edward.kram@bluearcenergy.com</p>
--	--

Transmission Line Availability Data Guidelines and Definitions

Copyright © 2003 by SGS Statistical Services, Cazenovia, NY and Blue Arc Energy Solutions, Inc., LaGrange, IL

The Transmission Line Availability Data Guidelines and Definitions is copyrighted by SGS Statistical Services (SGS) and Blue Arc Energy Solutions, Inc. (BAES). License is provided for use of this document individuals and organizations for the purpose of collecting data and/or evaluating availability of electric transmission circuits and systems. This license does not provide for the sale of this document by any party without permission of SGS Statistical Services and Blue Arc Energy Solutions.

Publication Date: February, 2003

# Transmission Line Availability Data Guidelines and Definitions

## Table of Contents

<b>INTRODUCTION</b> .....	<b>1</b>
<b>Why is the Guideline Necessary?</b> .....	<b>1</b>
<b>Users of this Document</b> .....	<b>1</b>
<b>Items for Future Consideration of Transmission Circuit Availability</b> .....	<b>2</b>
<b>History and Background of the Development Process of this Document</b> .....	<b>3</b>
<b>Contributing Organizations and Individuals</b> .....	<b>5</b>
<b>1. SYSTEMS AND UNITS</b> .....	<b>6</b>
<b>1.1. Power System</b> .....	<b>6</b>
<b>1.2. Transmission System</b> .....	<b>6</b>
1.2.1. Bulk Power Transmission .....	7
1.2.2. Load Serving Transmission .....	7
1.2.3. Transfer Points.....	7
<b>1.3. Units and Components</b> .....	<b>8</b>
1.3.1. Units.....	8
1.3.2. Sub-Units .....	8
1.3.3. Component .....	9
<b>1.4. Transmission Units and Sub-Units</b> .....	<b>9</b>
1.4.1. Transmission Units .....	9
1.4.2. Transmission Sub Unit.....	9
1.4.3. Transmission Circuit (or Line) Units.....	10
<b>1.5. Terminals</b> .....	<b>11</b>
1.5.1. Transmission Terminals.....	11
1.5.2. Distribution Terminals .....	11
1.5.3. Substation .....	11
<b>1.6. System Protection</b> .....	<b>11</b>
1.6.1. Fault Interrupting Equipment .....	11
1.6.2. Protective Devices .....	12
<b>2. DEFECTS, FAILURES, AND FAULTS</b> .....	<b>12</b>
<b>2.1. Defect</b> .....	<b>12</b>
<b>2.2. Failure</b> .....	<b>13</b>
2.2.1. Active Failure .....	13
2.2.2. Passive Failure .....	13
2.2.3. Latent Failure .....	13
<b>2.3. Fault</b> .....	<b>13</b>
2.3.1. Short Circuit Fault .....	14
<b>3. DEPENDENCY AND COMMONALITY</b> .....	<b>14</b>
<b>3.1. Independent Mode</b> .....	<b>14</b>
<b>3.2. Dependent Mode</b> .....	<b>14</b>
<b>3.3. Common Mode</b> .....	<b>14</b>
3.3.1. Common Catastrophe.....	15
3.3.2. Common System Mode .....	15
<b>4. TRANSMISSION UNIT AVAILABILITY STATES</b> .....	<b>15</b>
<b>Figure 4.1: Availability States Diagram</b> .....	<b>16</b>
<b>4.1. Available State</b> .....	<b>16</b>
<b>4.2. Non-available States</b> .....	<b>16</b>
4.2.1. Non-Outage States .....	17
4.2.2. Outage States .....	17
<b>5. RESTORATION TO AVAILABLE STATE</b> .....	<b>19</b>
<b>5.1. Outage Restoration</b> .....	<b>19</b>
<b>5.2. Repair Time</b> .....	<b>19</b>

# Transmission Line Availability Data Guidelines and Definitions

## Table of Contents

<b>5.3. Transfer Point Restoration</b> .....	<b>20</b>
5.3.1. Transfer Point Restoration, Transmission Circuit .....	20
5.3.2. Transfer Point Restoration, Transmission Circuit Section and Transfer Point .....	20
<b>5.4. Customer Restoration</b> .....	<b>20</b>
5.4.1. Customer Restoration, Transmission Circuit .....	20
5.4.2. Customer Restoration, Transmission Circuit Section and Transfer Point .....	21
<b>5.5. Flow Restoration</b> .....	<b>21</b>
<b>5.6. Deferred Restoration</b> .....	<b>21</b>
<b>5.7. Permanent Restoration (Restoration to Available State)</b> .....	<b>21</b>
<b>6. CUSTOMER IMPACT</b> .....	<b>22</b>
<b>6.1. Customer Impact Applicability Table</b> .....	<b>23</b>
<b>6.2. Disconnected Real-time Load</b> .....	<b>24</b>
6.2.1. Partially Disconnected Flow.....	24
<b>6.3. Disconnected Real-time Customers</b> .....	<b>24</b>
<b>6.4. Disconnected Real-time Generation</b> .....	<b>24</b>
<b>6.5. Actual Load Interrupted</b> .....	<b>24</b>
6.5.1. Interrupted Flow .....	24
<b>6.6. Actual Customers Interrupted</b> .....	<b>24</b>
<b>6.7. Actual Generation Interrupted</b> .....	<b>24</b>
<b>7. NON-AVAILABILITY ROOT CAUSE DESCRIPTION</b> .....	<b>24</b>
<b>7.1. Failure Cause Classification</b> .....	<b>25</b>
7.1.1. Terminal Equipment.....	25
7.1.2. System Protection.....	25
7.1.3. Lines .....	25
7.1.4. Weather, other than lightning.....	25
7.1.5. Lightning Only .....	25
7.1.6. Vegetation.....	25
7.1.7. External.....	25
7.1.8. Human Factors .....	26
7.1.9. Other .....	26
7.1.10. Unknown .....	26
<b>7.2. Non-Failure, Non-Fault Causes</b> .....	<b>26</b>
7.2.1. Operational Outage.....	26
7.2.2. Maintenance and Construction .....	26
7.2.3. Third Party Request.....	26
<b>7.3. Major Event Classification</b> .....	<b>26</b>
<b>7.4. Multiple Contingency States</b> .....	<b>27</b>
<b>8. DATA MANAGEMENT AND REPORTING GUIDELINES</b> .....	<b>27</b>
<b>8.1. Unit Identification [B]</b> .....	<b>27</b>
8.1.1. Unit Hierarchy [A].....	28
8.1.2. Unit Serialization and Traceability [A] .....	28
<b>8.2. Defect, Failure and Fault Identification [A]</b> .....	<b>28</b>
<b>8.3. Dependency and Commonality [A]</b> .....	<b>28</b>
<b>8.4. State Identification</b> .....	<b>28</b>
8.4.1. Units Recorded in State Changes .....	28
8.4.2. Recording for Any State Change [B].....	29
8.4.3. Use of Date and Time Formats [B] .....	29
8.4.4. Non-Outage States [A].....	29
8.4.5. Outage States .....	29
<b>8.5. Restoration to Available State</b> .....	<b>29</b>
<b>8.6. Customer Impact</b> .....	<b>30</b>
<b>8.7. Non-Availability Root Cause Description</b> .....	<b>30</b>

**Transmission Line Availability Data Guidelines and Definitions**  
**Table of Contents**

<b>9.</b>	<b>DIAGRAMS</b> .....	<b>31</b>
<b>9.1.</b>	<b>System Diagram and Transfer Points</b> .....	<b>31</b>
<b>9.2.</b>	<b>Units and Sub-Units</b> .....	<b>34</b>
<b>9.3.</b>	<b>Station Unit Example</b> .....	<b>35</b>
<b>9.4.</b>	<b>Units with Normally Open Breaker configurations</b> .....	<b>36</b>
<b>9.5.</b>	<b>Transmission Circuit Unit Examples</b> .....	<b>37</b>
<b>9.6.</b>	<b>Transmission Circuit Segment Examples</b> .....	<b>38</b>
<b>9.7.</b>	<b>Customer Impact Examples</b> .....	<b>39</b>
<b>9.8.</b>	<b>Outage Restoration Diagram</b> .....	<b>40</b>
<b>9.9.</b>	<b>Data Guidelines and Definitions, Summary Block Diagram</b> .....	<b>41</b>
<b>10.</b>	<b>APPENDIX</b> .....	<b>A</b>
<b>10.1.</b>	<b>Endnotes</b> .....	<b>A</b>

## Introduction

This document is intended to provide a comprehensive guideline for definitions associated with the collection of data to assess the availability of electric transmission circuits and systems. The audience for this document is transmission owners, operators, regulatory authorities and other stakeholders in the electric transmission industry.

*It must be emphasized that this document, in its entirety, is not universally applicable to every transmission system.*

Each transmission system has its own unique set of availability requirements, dictated by its original design and construction and customer service requirements. For instance, in the United States, some systems are transmission-only providers and do not have retail customers. Others fit a more traditional vertically-integrated electric utility, with generation, transmission and distribution. Consequently, users of this document must assess which elements are directly applicable to the transmission assets they are evaluating.

To date, there have not been extensive regulatory requirements regarding transmission reliability. This contrasts with many regulatory requirements or goals which apply to electric distribution systems. Because regulatory bodies have not implemented performance reporting or requirements, there has not been standardization of definitions. *Regulatory authorities must be especially discriminating in evaluating which elements of this document are necessary to evaluate transmission system performance. Not all Guideline elements are necessary or desirable from a regulatory standpoint.*

### Why is the Guideline Necessary?

As the US transmission industry transitions towards open access and independent operating authorities, groups of transmission owners will become part of the same regional transmission organization. Common definitions for availability data are imperative when multiple transmission owners are operated by the same authority in order to permit the evaluation of historical performance based on availability or outages. Despite this evolving need, in early 2003 the industry lacked common definitions and guidelines to collect and manage transmission unavailability data.

The definitions herein relate primarily to *transmission outage data* (both *forced* and *planned*) and other circumstances which limit transmission circuit and system availability. The definitions and underlying data provide the basis to evaluate *historical* availability or reliability of transmission circuits and systems.

Transmission reliability has traditionally meant *security* and *adequacy*. Security of a transmission system helps ensure that a given event (e.g., an outage) will not compromise the transmission system to such an extent that can result in the collapse of the electric delivery system. Adequacy means that facilities are sufficiently designed to meet functional requirements for safe, reliable operation. Standards and practices for security and adequacy have been thoroughly developed and managed in the United States by the North American Electric Reliability Council (NERC) and its affiliated regional reliability councils. In many respects security and adequacy may be considered as *prospective reliability management* with the development of well defined planning and operations procedures.

Transmission availability data, on the other hand, has not been as thoroughly considered by the transmission industry in the United States. Almost all transmission owners have some form of outage data collection in place. But only a minority is very advanced in the collection and analysis methods, in contrast to information and data necessary for security and adequacy planning. The common thread to outage data in the US is the lack of common definitions and guidelines to collect and manage this data.

### Users of this Document

This document, first and foremost, should be viewed as a tool to improve reliability decision support through *empirical reliability analysis* using improved and consistent definitions and data

collection. *Empirical reliability analysis* forms the basis for *retrospective reliability analysis*. Having a complete and consistent set of definitions allows for the use of availability data on a within- and between-system basis for:

- Transmission Planning (inferring probabilistic estimates of circuit failures)
- Maintenance Management (identifying opportunities using historical performance)
- Design Standards (identifying under-performing designs)
- Regulation and Performance-Based Rates
- Defining Reasonable Service Quality Expectations for Customers.

### **Items for Future Consideration of Transmission Circuit Availability**

The Guideline is as complete as possible, given the state of the industry in early 2003. It should serve well for at least the next five to ten years. There are, however, many aspects of transmission system availability which are not contained in this document because of its scope, amount and type of data available or lack of consensus from the participating systems. Major areas for future consideration include:

Performance Measures: This document does not address the definitions, formulas or calculation of empirical reliability performance measures. It does, however, provide the basis for almost any conceivable performance measure by insuring complete data is collected.

CIGRE, IEEE and individual systems have developed a variety of transmission performance metrics, in all cases these measures rely on computation of averages. Because transmission availability data is highly skewed, such measures are usually inappropriate and can be misleading to assess reliability. A variety of non-parametric statistics for reliability analysis are more appropriate, but there is neither general acknowledgement of these measures nor knowledge of these statistical methods in the industry. Further, a full consideration of appropriate statistical methods for empirical reliability performance measurement would have required significantly more time and contributors.

Market and Economic Impacts of Transmission Unavailability: With the implementation of Locational Marginal Pricing and other methods to value transmission services, it may be possible to quantify the impact on energy markets due to the lack of transmission availability. At the present time, no transmission owners or operators routinely calculate and retain information related to the impact of all outages on energy markets (i.e., archived data on the actual or potential impact of each and every outage). Further, while the US Federal Energy Regulatory Commission has considered rules on Standard Market Design (SMD), there is debate whether SMD should apply to all transmission systems. At some future date, a standard method to quantify the market impact of outages should be defined.

Economic impacts of outages are the effects of supply interruptions on consumers. This information would require an estimate of economic losses for each customer served when a delivery point is interrupted; this was beyond the scope of this document.

Transmission Equipment and Substations: This document presents Guidelines for *transmission circuits*. While the majority of transmission forced outage events affect circuits, outages of transmission equipment within terminals and substations also affect transmission system availability. Transmission equipment and substations present many challenges for the development of guidelines for data collection; this was beyond the scope of this document.

Outage Cause Description: There are general categories contained in this document for classifying root cause of transmission outage events. Additional detail is needed. In Draft 2 of this document, a section was contained to classify all events as *within* or *outside* of design standards. This would classify outage events by implication as either *preventable* or *non-preventable*. Separation of failures into these two categories can provide significant information on inferior designs and practices to asset managers. Transmission owners expressed concern that the random nature of outages is such that the occurrence of a *preventable* outage may be

misconstrued or misused in our litigious society. Event classification was dropped by consensus, but it should be revisited in the future.

### **History and Background of the Development Process of this Document**

The development of the Guideline, first and foremost, was intended to produce a practical, consensus document. To this end, the process involved a total of 37 transmission systems or other transmission entities and 2 consultants participating in 3 conferences. All work on this document was on a strictly voluntary basis by all parties and no transmission entity led or dictated the development process in any manner.

In the late 1980's both IEEE and CIGRE developed definitions for transmission outage data. A number of regional reliability councils and power pools implemented data collection and reporting procedures. Most of these efforts centered on bulk power systems. In the 1990's many of these multi-system organized data collection efforts faltered. Concurrently, individual systems established electronic databases, mostly using their own definitions and methods for collecting data.

As the 1990's progressed and the electric industry restructured, many systems had an increasing interest in performance comparisons and benchmarking. SGS Statistical Services began offering its annual Transmission Reliability Benchmarking Study in 1995. As part of benchmarking, consistency of data was very important. Because of differences in data collection definitions it was necessary to conduct benchmarking on the "lowest common denominator" of available data. SGS Statistical Services and the Transmission Reliability Benchmarking Study participants all recognized that additional benchmarking comparisons would be available with little additional effort beyond current data collection. This information would also help transmission owners make better planning and maintenance decisions.

Upon completion of its seventh annual Study in May 2001, a consensus was developed among the 30 participating systems to conduct a conference to review current industry data collection and management practices and ideas for improvements. The first conference was held on October 30 and 31, 2001 in Providence, RI. The meeting was organized and conducted by SGS and was hosted by National Grid USA.

The October 30-31 conference concluded with a commitment to produce a Guideline for transmission circuit availability data. The process distilled the various existing standards and objectives to update the existing standards and practices to the new transmission environment. Four working groups consisting of volunteers were established to produce the Guidelines:

Working Group 1: Circuit, Outage and Restoration Definition

Working Group 2: Customer Impact

Working Group 3: Non-Fault Outages

Working Group 4: Outage Cause Description

It was intended that the authorship of the Guideline be distributed amongst working group volunteer members, with SGS Statistical Services and Blue Arc Energy Solutions, Inc. providing facilitation. The goal was to produce a draft Guideline in spring 2002. Through March 2002, the working groups experienced a variety of success and participation. It was decided to expedite the process with Blue Arc Energy Solutions and SGS Statistical Services assuming the authorship of the Guideline and utilize the participants for guidance and review.

Draft 1 of the Transmission Line Availability Data Guidelines and Definitions was completed on April 15, 2002. The draft was posted and circulated to participating individuals and systems. Draft 1 was reviewed on May 13, 2002 at a conference in Tucson, AZ prior to the annual SGS Transmission Reliability Benchmarking Study conference. SGS organized and hosted the meeting. A total of 38 people participated in the review; the consensus of the review meeting was that major revisions and refinements of Draft 1 were required.

During summer 2002, additional review comments were solicited. The second draft was completed on August 28, 2002 and distributed. On September 24, 2002, Draft 2 was reviewed at a meeting in Waukesha, WI, hosted by American Transmission Company and organized by Blue Arc Energy Solutions and SGS Statistical Services. Five review groups further refined document sections and requested clarification. Major revisions of Draft 2 were not dictated. Fall of 2002 also provided the opportunity to share work on the Guideline at meetings of the Western Electric Coordinating Council, Electric Power Research Institute and Edison Electric Institute.

The Final Draft was completed in January 2003. It was circulated among participating organizations for final proofing. On February 24, 2003 it is issued and will be freely circulated in the industry and with other stakeholders. It is hoped after issuance of the Guidelines that transmission owners, operating authorities, regulatory authorities and other stakeholders consider the Guideline's applicability to transmission reliability management.

The Final Draft is a "free-use" document; its authors, reviewers and participants only request that it be used with attribution. This document may not be reproduced for sale in any manner without expressed written permission of Blue Arc Energy Solutions and SGS Statistical Services.

## Contributing Organizations and Individuals

NOTE: Listing of systems or individuals is an acknowledgement of participation and/or contribution and does not constitute acceptance or endorsement of the Guideline.

System	Conference Date			Persons Contributing
	10/30-31/01	5/13/02	9/24/02	
Allegheny Power	X	X		Ralph Cannon, Diane Lepovsky
American Electric Power	X		X	Ali Al-Fayez, Mike Higgins, Mike Romine
American Transmission Co.	X	X	X	Peter Burke
Arizona Public Service		X		Anwar Hameed, Donald Lamontagne
Bonneville Power Administration		X		Roy Ellis
California ISO		X	X	Tom Halford
City Public Service – San Antonio	X		X	Robert Fix, Cathleen Ballard
ComEd (an Exelon Company)		X	X	Jeff Gillen, John Kruse
Dominion Virginia Power	X	X		Ron Broocks, Don Koonce
Duke Electric Transmission	X	X		Gary Brad
ECAR Executive Office	X	X	X	Jeff Mitchell
Entergy Transmission	X	X	X	Robert Gibbs, Tessa Schwartz, Gerald Gibson
EPRI			X	Ram Adapa
First Energy	X	X		Harold Lubbeck
Georgia Power		X	X	Greg Gaston, Bill Holcombe
Georgia Transmission Corp.	X	X	X	Kevin Luke, Doug Maddox
GPU Energy	X	(merged)		David Barber
Idaho Power	X	X	X	Rich Canderan
Keyspan Energy		X	X	Polina Adelson, Stephen Wasylenko
MAIN			X	Alex Schneider
Michigan Electric Transmission Company			X	David Tates
Montana Power	X	(merged)		Steve Luther
National Grid USA	X	X		Bob Bell, Kurt Kach
Niagara Mohawk	X	(merged)		Jim Dillon, +1
Northeast Utilities	X	X		Rick Halleck, Ben Richards
NorthWestern Energy		X	X	Steve Luther
NSTAR	X			Greg Sullivan, John O'Brien
Oncor Transmission (TXU)	X	X	X	Donny Helm, Jim Mackey
PJM-ISO	X			Andy Ott
Progress Energy	X	X	X	Mark Matthews, Robert Lord
Public Service Electric & Gas	X	X	X	Joe Arone, Peter Kudless
San Diego Gas & Electric		X		Anita Hoyos
Salt River Project	X	X	X	Joel Chang, Jose Silva
South Carolina Electric & Gas		X		Fred Brooks, Fred Cain
Tennessee Valley Authority	X	X	X	Scott Clemons
Xcel Energy		X	X	Steven Quade, Michelle Wood

# 1. Systems and Units

## 1.1. Power System

A group of one or more generating sources, substations and connecting transmission and distribution circuits operated under common or cooperative management or supervision to supply energy.<sup>1</sup> A system is a large group of components connected or associated in a fixed configuration to perform a specified function<sup>2</sup>.

The Generating System represents the contributions of one or more generating sources to a power system. They are connected to the delivery system at Production Transfer Points (see 1.2.3.1).

The Delivery System includes assets from the Generating System, or Production Transfer Points, to the customer service connection. See Figure 1-1.

NOTE: All figures and diagrams in this document are represent “typical” configurations and should not be considered all inclusive. Many other configurations can and do exist within the industry. It is impossible to represent all possible configurations in figures.

Figure 1-1 Power System Diagram

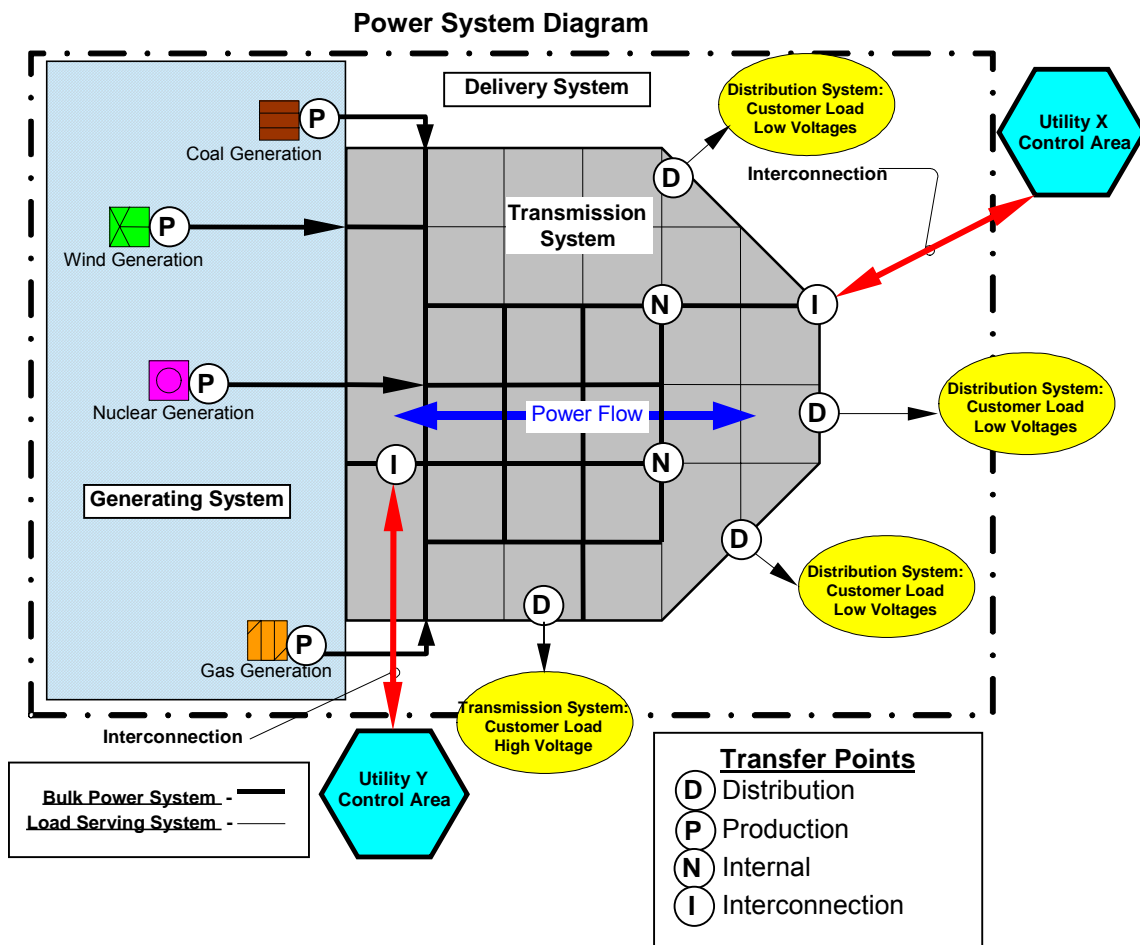

## 1.2. Transmission System

The transmission system is comprised of the high voltage portion of a power system used primarily for the purpose of transferring (delivering) energy from producers to distributors

and/or consumers. The US Federal Energy Regulatory Commission (FERC) established a “seven factors” test to define distribution system assets not subject to FERC jurisdiction<sup>3</sup>.

The transmission system may be viewed as the portion of the electric delivery system which does not qualify as distribution under the FERC’s seven factors; there is no specific distinction for the operating voltage to define the transmission system.

Alternatively, the transmission system is the aggregate of all the power transmission facilities operated under common or cooperative management or supervision to transfer electric energy<sup>4</sup>.

The transmission system is comprised of the Bulk Power Transmission, Load Serving Transmission, Transfer Points and Terminals.

NOTE: A transmission system may also be called a transmission grid or transmission network.

### **1.2.1. Bulk Power Transmission**

This is the portion of the transmission system which is characterized by units of (1) generally high or extremely high voltages (> 200kV) (2) movement of electricity over longer distances and (3) very few, if any, Distribution Transfer Points. In some instances units below 200kV may be part of the bulk power system.

### **1.2.2. Load Serving Transmission**

This is the portion of the transmission system which is characterized by units of (1) lower voltages (< 200kV) (2) movement of electricity over shorter distances and (3) primary purpose is to serve Distribution Transfer Points. In some instances units above 200kV may be part of the Load Serving Transmission system.

### **1.2.3. Transfer Points**

A transfer point is where energy is received, distributed or transferred to/from the transmission system by a transmission circuit. There are four types of transfer points: Production Transfer Point, Distribution Transfer Point, Internal Transfer Point, and Interconnection Transfer Point. Transfer points are demarcations of responsibility and function. See Figure 1-1 and Diagram 9.1..

#### **1.2.3.1. Generation Transfer Point**

A Generation Transfer Point is where the transmission system receives energy from a generating station.

NOTE 1: A Generation Transfer Point is generally the high-side disconnect of a GSU transformer. Ownership and maintenance responsibilities may place the Generation Transfer Point at another location. Regardless of how ownership defines it, the Generation Transfer Point, for reliability reporting, is considered unavailable if the transmission system is unable to receive energy at the Production Transfer Point.

NOTE 2: A Transfer Point may also be referred to as a Point of Receipt, (POR), or Production Transfer Point.

#### **1.2.3.2. Distribution Transfer Point**

A Distribution Transfer Point is a point where the transmission system delivers energy to a wholesale customer or a distribution system.

NOTE 1: A Distribution Transfer Point is generally the high-side disconnect of a power transformer. Ownership and maintenance responsibilities may place the Distribution Transfer Point at another location. Regardless of ownership, the Distribution Transfer Point for reliability reporting is considered interrupted if the transmission system, under normal operating configuration is unable to supply energy at the high-side disconnect of a power transformer.

NOTE 2: A Distribution Transfer Point may also be referred to as a Point of Delivery (POD), or Distribution Delivery Point.

#### **1.2.3.3. Internal Transfer Point**

An Internal Transfer Point is a point where a higher voltage transmission circuit transfers energy to a lower voltage transmission circuit(s) of the same transmission system owner.

#### **1.2.3.4. Interconnection Transfer Point**

An Interconnection Transfer Point is a point that is an interface between two transmission systems of different owners. Energy is either received or delivered between transmission systems at these points. The Interconnection Transfer Point may be any point on a transmission circuit (e.g., terminal, circuit breaker, structure, mid-span, jurisdictional boundary, etc).

NOTE 1: An Interconnection Transfer Point may also be defined by ownership and maintenance responsibilities. Regardless of ownership, the Interconnection Transfer Point for reliability reporting is considered unavailable if the transmission system is unable to receive or deliver energy at the Interconnection Transfer Point for a given transmission owner.

### **1.3. Units and Components**

A power system is composed of *units*, *sub-units* and *components*. Units, sub-units and components may be regarded as an entity for purposes of outage data analysis and reliability modeling<sup>5</sup>.

#### **1.3.1. Units**

A unit is an entity for reporting purposes which is defined by boundaries of fault-interrupting terminations that are designed to automatically and completely isolate that entity from the power system under fault conditions by actuation of its system protection. A unit has a designed capacity within those boundaries to provide specific function(s) to system users and operators.

Unit examples include: circuits, transformers, buses, regulators, phase shifting transformers, inductors, capacitors, and generators.

#### **1.3.2. Sub-Units**

A sub-unit is a portion of a unit which is defined by boundaries of terminations that are neither designed nor capable of complete and automatic isolation of the unit from the power system under fault conditions. Sub-Units are one or more sets of components which are functionally related and are nested inside a Unit. Sub-units may share partial boundaries with units of which they are part.

NOTE 1: Examples of sub-unit boundaries are manual disconnects, which are not designed for fault interruption. See Diagram 9.2. Other examples are circuit switchers which have limited fault clearing ability and are not designed for multiple re-closing. These typically denote sub-unit boundaries since a larger protected zone is evidenced by breakers that are designed to clear faults under all fault conditions.

NOTE 2: A Termination (1.5.2.1) is a sub-unit, and can be fault interrupting equipment (a circuit breaker); however by itself it cannot isolate from the power system.

NOTE 3: Other sub-unit examples include: circuit taps, circuit sections, circuit segments. Sub-units can often be remotely operated and may include automatic operations, but commonly are limited to non fault operations or sectionalizing operations post fault interruption.

### **1.3.3. Component**

A component is an entity that performs a major operating function.

NOTE: Components may be divided into two general classes: Major Components and Auxiliary Components. For purposes of recording outage data, auxiliary components are included with the item of equipment which they are a part.<sup>6</sup>

Examples of Major Components: Transformer tap-changer; circuit breaker contact mechanism.

Examples of Auxiliary Components: Transformer tap-changer motor or tap-changer arcing contacts; circuit breaker main contacts or circuit breaker arcing resistors, respectively.

## **1.4. Transmission Units and Sub-Units**

Transmission Units are one or more sets of components of the transmission system used for the transfer of energy between the generating system and distribution system. Transmission Units consist of Terminal Units, and Circuit Units. Transmission units are the basic elements for availability reporting.

### **1.4.1. Transmission Units**

A transmission unit is a transmission entity for reporting purposes which is defined by boundaries of fault-interrupting terminations that are designed to automatically and completely isolate that entity from the power system under fault conditions by actuation of its System Protection (section 1.7). A unit has a designed capacity within those boundaries to provide specific function(s) to system users and operators.

Transmission unit examples include: circuits, transformers, buses, regulators, phase shifting transformers, inductors, or capacitors.

#### **1.4.1.1. Terminal Units**

Terminal units are transmission units that are located within a terminal. They include transformers, regulators, capacitors, inductors, phase shifting transformers, and buses.

##### **1.4.1.1.1. Bus**

A bus is a type of transmission unit located at terminal that is comprised of a conductor or group of conductors that serves as a node for two or more units, circuits, taps, or items within a terminal.<sup>7</sup> The bus serves as a common connection point for these elements.

NOTE: In certain terminal configurations, such a “ring bus” configuration, there may only be one circuit termination physically on a bus, however the bus provides a common connection to other bus units at its boundary. See Diagram 9.2.

#### **1.4.2. Transmission Sub Unit**

A transmission sub-unit is a portion of a transmission unit entity which is defined by boundaries of terminations that are neither designed nor capable of complete and automatic isolation of that entity from the power system under fault conditions.

A Transmission Sub-Unit is one or more sets of components nested inside a Transmission Unit. Sub-units may share partial boundaries with units of which they are part. See Diagram 9.3.

##### **1.4.2.1. Termination**

A termination is a transmission sub-unit located in a terminal consisting of power equipment and associated components that define the boundary between adjacent

transmission units or sub units. Terminations are subdivided into fault interrupting and non-fault interrupting. They may include components and auxiliary components such as: surge protective devices, voltage transformers, potential devices, strain insulators, coupling capacitors, etc.<sup>8</sup>

NOTE 1: Certain terminations, such as circuit breakers form a boundary between adjacent units and therefore may be part of more than one unit.

NOTE 2: "Normally Open" circuit breaker configurations exist for system security and adequacy design considerations (see Diagram 9.4). The Normally Open status does not alter unit boundaries. The Normally Open breaker does not constitute a Non-available state for the unit(s) of which the breaker is part.

### **1.4.3. Transmission Circuit (or Line) Units**

A transmission circuit is a transmission unit that transports power between at least two terminals and is bounded by terminations defined by a protected zone, where at least one termination is located at a transmission terminal.

A transmission circuit is generally part of a networked grid, but some transmission circuits may be radial (e.g., from a generation source to the transmission system or from the transmission system to directly-served transmission voltage customers or distribution transfer points).

A circuit may contain sub-units such as multiple sections, taps, tap points, and segments.

A transmission circuit is most often a simple two terminal configuration transmission unit. Configurations vary in complexity as illustrated by example in Diagram 9.5.

NOTE 1: Transmission Line and Transmission Circuit are equivalent and used interchangeably.

NOTE 2: A circuit must include all fault-interrupting equipment required to interrupt all sources of fault current for faults occurring on any component of the circuit.

NOTE 3: Ownership boundaries between the transmission owner and customers (generation, distribution, other transmission owners, etc) may be crossed by a transmission circuit. It is the location of fault interrupting unit terminations that define the circuit, not ownership. See Diagram 9.5.

#### **1.4.3.1. Tap Point**

A tap point is a point on a multi-terminal transmission circuit where portions leading, directly or indirectly, to three or more terminals are joined.<sup>9</sup> A circuit tap point represents the connection of a circuit tap to a circuit. See Diagram 9.6.

#### **1.4.3.2. Tap**

A tap is a portion of a transmission circuit that is bounded by a circuit tap point and a circuit termination. A Tap is a sub-unit of a transmission circuit unit. See Diagram 9.6.

#### **1.4.3.3. Section**

A section is a portion of a transmission circuit bounded by two terminations and/or circuit taps.<sup>10</sup> A circuit section is a portion of a transmission circuit that may be fully isolated by switch devices from other sections of the same transmission circuit. A Section is a sub-unit of a transmission circuit unit. See Diagram 9.6.

A circuit section is identified by its unit transmission circuit ID and a second, separate unique identifier.

#### **1.4.3.4. Segment**

A segment is a portion of a circuit that has a particular type of construction or design and therefore may be regarded as a separate entity for purposes of reporting and analyzing outage data (e.g., two contiguous overhead segments, one wood pole construction the other steel lattice).<sup>11</sup> See Diagram 9.6.

### **1.5. Terminals**

A Terminal is a functional facility (usually a substation) which includes units, sub-units, and components (such as bus sections, circuit breakers, and protection systems), where transmission units terminate.<sup>12</sup> Terminals, also called stations, have physical demarcations including fences, walls, or other barriers for safety and security. Terminals may be subdivided into transmission terminals and load serving terminals.

NOTE 1: Some terminals may serve both bulk power and load serving functions, in addition some terminals may serve both transmission and distribution functions.

NOTE 2: Terminals, although comprised of units and sub-units, are not themselves a unit. The terminal is the demarcation of property where these units are located. Power is transmitted on the units, and thus through the terminal, but not on the terminal. Similar discussions apply for circuits and right-of-way property.

#### **1.5.1. Transmission Terminals**

Transmission terminals serve transmission functions.

#### **1.5.2. Distribution Terminals**

Distribution terminals provide distribution or load serving functions.

#### **1.5.3. Substation**

A substation is a terminal that contains a transformer or transformation. It may contain switches, circuit breakers, buses, transformers, and voltage control equipment for switching power circuits, voltage control, and transforming power from one system to another.<sup>13</sup> Substations are classified as transmission or distribution depending on the function of the transformation.

### **1.6. System Protection**

A system of sensing, measurement, and actuation devices that detect abnormal conditions, faults and failures in power systems and power system units for the purpose of actuating fault interrupting equipment to safely and automatically isolate the unit from the power system.

System protection designs, or schemes, are organized to operate devices in a group(s) that are usually simultaneous, but may involve time delayed sequencing of automatic operations to complete the system isolation in multiple steps.

System protection components are protective relays, control and auxiliary relays, communication equipment and fault interrupting equipment (including primary fuses). Protection schemes isolate all sources of fault current into the circuit by initiating a trip signal to the fault interrupting terminal equipment or circuit breakers.

System protection is accomplished through the designed interaction of two main groups of components: fault interrupting equipment and protective devices.

#### **1.6.1. Fault Interrupting Equipment**

Fault interrupting equipment is high voltage power equipment capable of primary fault interruption. Most typically these are circuit breakers. The equipment is rated for levels of symmetric and asymmetric fault duty at which it can safely interrupt power system faults at high speed. Fault interrupting equipment has two functional states: trip (open) and close. This equipment is also referred to as the primary equipment, or primary fault

interrupting equipment, or primary voltage equipment. These terms refer to the voltage and current at which power transmission occurs and at which it is interrupted.

NOTE 1: Non fault interrupting equipment may have the ability to open or break load current and may have limited capability to break lower grade faults, but is generally unable to interrupt the most severe fault current. Motor operated, manual disconnects, circuit switchers and other load break devices fall into this category and are often used for normal switching isolation, but are not fault interrupting equipment.

NOTE 2: Primary fuses are fault interrupting equipment.

### **1.6.2. Protective Devices**

Protective devices are the components that sense and measure fault conditions and produce trip signals automatically as commands to primary equipment for the automatic isolation of the protected unit from the power system. These devices include but are not limited to protective relays, current transformers, and voltage transformers, transducers and auxiliary relays. These devices are also referred to as the secondary equipment, or secondary voltage equipment. This reference indicates the transformation of power conditions to measuring levels via transducers or transformations at which the protective devices operate.

#### **1.6.2.1. Protected Zone**

The protected zone is the boundary defined by the design of fault interrupting equipment and protective devices that performs fault clearing for a given transmission unit or units. The protected zone refers to the span of protection provided.

This normally refers to the breaker to breaker sections. In other contexts protected zone can refer to the percent of the circuit length, or reach, specific impedance relays can detect faults along the circuit. A transmission unit may be protected with multiple protected zones, within this other context.

System protection is often redundant. A transmission unit may be protected by multiple protected zones.

##### **1.6.2.1.1. Unit Protected Zone**

A unit protected zone is the protected zone for a specific unit.

## **2. Defects, Failures, and Faults**

Defects, failures, and faults define events and conditions that occur on power systems and their components which prevent or have the potential to prevent the transmission system from operating as designed. Defect is more generic, while failure is more specific and fault is a specific failure condition.

### **2.1. Defect**

A defect is a departure of any characteristic of an item from requirements. A defect is a design, manufacturing, construction, or service life related flaw or condition in a transmission unit, equipment, or component that may or may not contribute to its failure. Examples of typical examples include: broken strands in a conductor, a leak in a transformer tank, or a defective trip coil.

NOTE 1: The requirements may or may not be expressed in the form of a specification.

NOTE 2: A defect may or may not affect the ability of an item to perform a required function.<sup>14</sup>

Defects are often found during preventive maintenance, inspection, or patrol. Categorization of defects as failures may depend upon the maintenance and operating standards and practices of each transmission owner.

## **2.2. Failure**

A failure is a condition that renders a unit incapable of performing an intended function. A failure can refer to a condition for an entire system, individual unit or component. Failures may result in non-available states including outages.

### **2.2.1. Active Failure**

An active failure is a mode of failure which causes the operation of the primary protection zone around the failed component<sup>15</sup>. The term is used to describe conditions and effects after the fact. A short circuit failure resulting in an automatic outage is an example of an active failure.

### **2.2.2. Passive Failure**

A passive failure is a mode of failure which does not cause operation of circuit breakers or fuses<sup>16</sup>. The term is used to describe conditions and effects after the fact.

EXAMPLES: (1) A circuit breaker latch mechanism fails and spuriously operates resulting in a "false trip", although no fault condition exists. (2) A cracked or broken cross-arm is noted upon visual inspection during routine patrol of a transmission circuit, although the condition has not resulted in the activation of any system protection. Repairs are scheduled for a planned maintenance outage. However where market notice time limits exist, repairs scheduled with less than the advance notice requirement are considered a forced outage.

### **2.2.3. Latent Failure**

A Latent Failure is a defect which remains undetected until the component or item is called to perform a required function.<sup>17</sup> A latent failure is also a condition, if left unattended that will result in a failure. The term describes a passive failure mode that was hidden until a precipitating event. Once manifested latent failures can be classified passive or active.

EXAMPLES: (1) An SF<sub>6</sub> circuit breaker has a slow leak; if left unattended, the leak will eventually cause the breaker to fail to operate. (2) Cracked cross arms remain undetected by inspection; however hurricane force wind conditions force some of them to break and result in phase to phase short circuit faults detected by system protection operation during a temporary outage. The resulting circuit patrol finds the circuit re-energized with several broken cross arms and several cracked cross arms. The subsequent repair and investigation determines a latent failure pre-existed on all cracked and broken arms. From fault-distance data it is determined that specific broken arms resulted in an active failure between two towers, while other cracked and broken arms resulted in a passive failure that was also subsequently repaired.

## **2.3. Fault**

A fault is a failure condition characterized by asymmetric or unbalanced three-phase voltage or current conditions. System protection detects faults through the measurement of electrical parameters such as voltage and current. Certain units such as transformers or generators often have additional system protection using other parameters (e.g., sudden pressure, machine frequency, etc.).

System conditions such as under or over frequency and instability are not faults and refer to conditions of the transmission system. System protection designed for this condition can result in outages to transmission units.

### **2.3.1. Short Circuit Fault**

A fault that occurs when components of a power system are brought in contact with ground potential or each other such that the designed insulating medium is compromised to the point of failure.

Short circuit faults are the most prevalent faults that occur on transmission circuits.

NOTE: When possible, outage records should identify which phase(s) were involved in a fault.

#### **2.3.1.1. Single Phase-to-Ground Fault**

This is a short circuit fault having one phase short circuited to ground.

#### **2.3.1.2. Two Phases-to-Ground Fault**

This is a short circuit fault having two phases short circuited to ground.

#### **2.3.1.3. Three Phases-to-Ground Fault**

This is a short circuit fault having three phases short circuited to ground.

#### **2.3.1.4. Phase-to-Phase Fault**

This is a short circuit fault having two or more phases short circuited with one another.

## **3. Dependency and Commonality**

Dependency and Commonality define the scope and span of an event by characterizing the initiating unit or component of faults or failures and the time-order of any other affected units and components by the initial event.

Accurate characterization of Dependency and Commonality are necessary to assess the occurrence or probabilities of multiple contingency events.

### **3.1. Independent Mode**

The initiating or primary fault or failure occurs from conditions within the component or unit.

### **3.2. Dependent Mode**

The initiating fault or failure occurs from conditions external to the component or unit. A dependent mode outage is dependent on the occurrence of, and is preceded by an independent outage.

EXAMPLE 1: The occurrence of an independent mode outage on one circuit of a double circuit transmission right of way is followed by the removal of the second circuit due to overload.<sup>18</sup> The second circuit outage is a dependent mode outage due to the initiating independent outage.

EXAMPLE 2: Due to improper relaying coordination between terminals a second transmission unit is outaged for a fault on an adjacent unit. The second outage is dependent on the unit where the fault occurred.

EXAMPLE 3: An automatic relay fails to perform the auto restoration of a transmission unit after an independent primary transient fault. The resulting temporary outage is dependent upon the initial independent fault event and the dependent mode failure of the reclosing relay. The unit would have experienced only a transient outage if not for the reclosing relay failure.

### **3.3. Common Mode**

A common mode outage is an event where near-simultaneous, multiple faults or failures are not dependent upon one another for initiation. The root cause is not within another unit.

Example 1: A tornado causes the failure of transmission towers that support two or more transmission circuits, thus causing outages to both circuits.<sup>19</sup>

Example 2: A station battery fails resulting in Emergency outages to all units at the station.

### **3.3.1. Common Catastrophe**

A common catastrophe occurrence is when numerous, similar faults or failures occur at an elevated rate in a compact and contiguous geographic area in a short time period.

NOTE: Examples may include major storms (hurricanes, ice storms), fires, earthquakes, floods, sabotage. There may not be a common component failure as in the Common Mode examples however the external cause is the same.

### **3.3.2. Common System Mode**

The initiating cause is abnormal frequency or voltage, instability, or other system conditions not attributable to a particular failure or cause within the transmission unit(s) outaged.

NOTE 1: Examples include: (1) sudden abnormal frequency or voltage due to the loss of a generating unit; (2) slow decline in frequency due to a sustained period of under generation; (3) sudden abnormal voltages due to loss of a system tie (or a neighboring utility's tie); (4) voltage collapse under heavy load conditions due to inadequate vars for the amount of load.

## **4. Transmission Unit Availability States**

The following definitions are classified as terms that define the status of transmission units, and associated entities of these systems as indicated within the Availability States (Figure 5-1) from top to bottom.

NOTE 1: States are divided into two classes: Available and Non-Available States.

**Figure 4.1: Availability States Diagram**

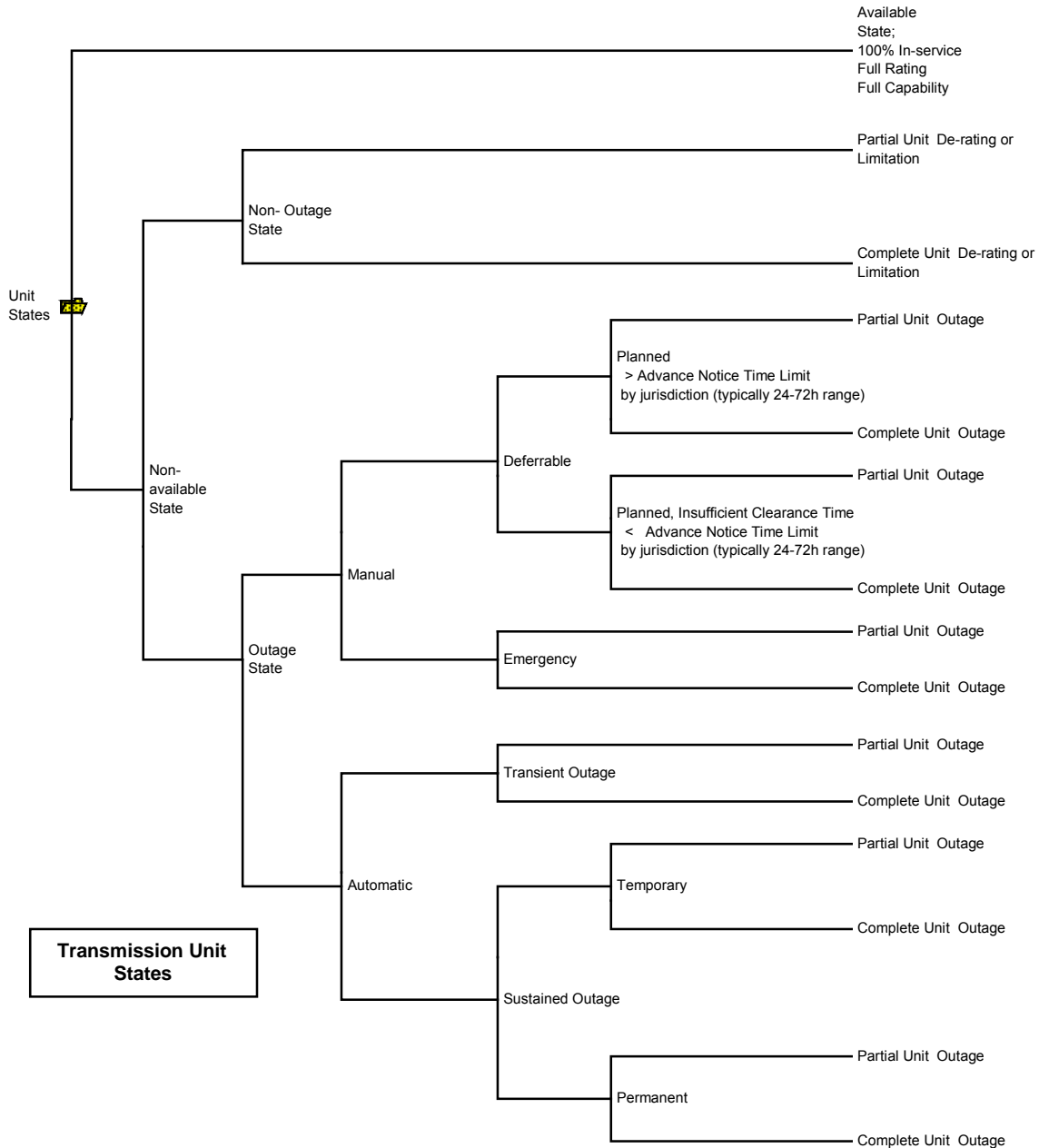

**4.1. Available State**

The condition of a transmission unit or component that is able to perform fully in accordance with its design.

**4.2. Non-available States**

Non-available states are transmission unit states that are characterized by a failure to meet the design capability, functionality or by an outage state condition. Non available states meet one or more of the following conditions:

- (1) An interruption or outage has occurred within the unit's protected zone.
- (2) A design capacity limitation has occurred within the protected zone (i.e., de-rating).
- (3) A failure or defect has occurred within the protected zone (i.e., regulator is unable to regulate due to stuck tap changer).

NOTE 1: Non-available states are not necessarily indications of transmission unit faults or failures. Non-available states are often for non-failure causes such as routine maintenance or operating conditions.

NOTE 2: Non-available states may be considered forced or not forced. A forced state is one when there is no other option than to remove a unit from full availability.

NOTE 3: Where applicable, market driven prior notice requirements are intended for efficient and nondiscriminatory economic markets. In these environments "Forced" indicates a non-market cause of unavailability although the unit may be fully available during the market time limit notice (24 to 72 hours depending on jurisdiction) with none of the above conditions applicable until the unit outage occurs.

#### **4.2.1. Non-Outage States**

Non-outage states are non-available states where a full unit remains in service characterized by a restriction, constraint or inability to entirely perform the unit's intended or specified functions. Examples include: de-ratings, temporary repair conditions, loss of operational function, etc.

NOTE: The amount of de-rating is the measure of shortfall between actual capability and rated capability.

EXAMPLE: An example of a Non-Outage state can be expressed using Diagram 9.5. If a circuit breaker at Terminal 2 for Circuit 3 were temporarily opened (without de-energizing breaker) a Non-Outage state occurs on Circuit 3 and the adjoining bus unit.

#### **4.2.2. Outage States**

An outage state is a non-available state and an interruption of a transmission unit characterized by a loss of voltage on any portion or phase of the unit. The minimum duration of this condition is not within the scope of this document but is generally evidenced by an automatic circuit breaker operation. The definition of an interruption is left to IEEE technical committees; as such power quality events are not intended to constitute outage states. An outage state may not indicate any fault or failure. The majority of transmission time is for maintenance and system operation.

NOTE: An outage may or may not cause an interruption of service to customers, depending on the transmission unit and system design and configuration.

##### **4.2.2.1. Partial Outage**

A partial outage is unit which is partially isolated and the unit is not capable of flow to all terminals or sections. Some portion of the unit remains energized.

EXAMPLE: If in the EXAMPLE of section 4.2.1 the opened breaker is de-energized and isolated, by the opening of manual disconnects on either side of the breaker, for inspection maintenance, then a Partial Outage occurs for Circuit 3 and the adjoining bus unit.

##### **4.2.2.2. Full Outage**

A full outage state is a unit that is fully isolated and has zero voltage.

#### **4.2.2.3. Manual Outage**

A manual outage is an outage that is intentionally initiated, for any reason, by manual, supervisory control. These outages include deferrable and emergency outages.

##### **4.2.2.3.1. Deferrable Outage**

A deferrable outage is a manual outage that poses no immediate threat or danger to the public, customers, personnel or equipment. If necessary, a deferrable outage may be changed or canceled outright. A deferrable outage is not a forced outage.

###### **4.2.2.3.1.1 Planned Outage**

A planned outage is a deferrable outage that has been scheduled in advance (usually between 24 and 72 hours) in accordance with operating authority standards.

###### **4.2.2.3.1.2 Planned Outage, Insufficient Clearance Time**

A Planned Outage, Insufficient Clearance Time is a deferrable outage that has *not* been scheduled a minimum hours in advance (usually between 24 and 72 hours minimum) in accordance with operating authority standards. Under market driven systems this type of outage is labeled "Forced" if the advanced notice is less than the market notice time limit.

##### **4.2.2.3.2. Emergency Outage**

An Emergency Outage is a manual outage that poses immediate threat or danger to the public, customers, personnel or equipment. Emergency outages may be initiated for operating reasons or after identification of a latent failure or defect. An Emergency Outage may also be at the request of third parties such as a government agency, fire or police departments or right-of-way holder. An Emergency Outage is a forced outage.

#### **4.2.2.4. Automatic Outage**

Automatic outages are outages resulting from automatic switching operations. These are usually initiated through system protection schemes that detect and respond to system fault conditions. An Automatic Outage is a forced outage.

##### **4.2.2.4.1. Transient Outage**

A Transient Outage is an automatic outage which is automatically restored with no human intervention. Reclosing schemes have re-energized the unit after an established time and conditions (usually after a fault clearing period and in an established order).

##### **4.2.2.4.2. Sustained Outage**

Sustained outage is any automatic outage that is not a transient outage.

###### **4.2.2.4.2.1 Temporary Outage**

Temporary outages are sustained outages in which the restoration is completed manually by operating personnel. This may result after automatic restoration schemes have unsuccessfully restored the unit (reclosing relay failure) or reclosing has been intentionally disabled. Some transmission circuits do not have automatic restoration and can only be restored through manual control.

#### **4.2.2.4.2.2 Permanent Outage**

A permanent outage is a sustained outage that must be corrected by eliminating the fault, either by repair or replacement, before the unit can be returned to service.

### **5. Restoration to Available State**

The following sections identify how to capture and delineate each Non-Available State change required returning a transmission unit to the Available State. Because a transmission owner may be rewarded or penalized on the basis of its ability to restore full service at the lowest cost, accurate characterization of time intervals associated with Restoration to Available State is necessary.

Recording of all intervals associated with Restoration to Available State may not necessarily be applicable to every system. It must be recognized that considerable effort must be expended to record every interval; transmission owners, operators or regulators must carefully consider recording requirements.

The ability to restore is a complex balance of many factors including but not limited to: system conditions, external weather conditions and/or catastrophic impacts, safety and operational policies, system configuration, system geography, and available staffing. Comparison between systems should be handled cautiously since these factors are unique within each transmission system.

Non-Available States have an easily identifiable start time. Restoration to the Available State may be achieved in multiple steps, each of which has date and time delimiters. See Diagram 9.8.

Non-Available states may occur without a previous outage state but may ultimately require a subsequent outage to return the unit to an available state.

#### **5.1. Outage Restoration**

Outage Restoration is the date and time at which the transmission unit is re-energized to full rating after experiencing an outage state, but may or may not be fully functioning as-designed (e.g., a unit may remain in a non-outage state or remain temporarily repaired prior to Permanent Restoration).

NOTE 1: Complete outage restoration occurs when the entire unit is re-energized. A breaker may still remain open preventing unit availability however all constituent sub-units are completely energized.

NOTE 2: Partial outage restoration occurs when some constituent sub-units are energized while others are not. Generally partial outage restoration precedes complete outage restoration.

#### **5.2. Repair Time**

The Repair Time is the elapsed time from when repairs are authorized to commence by the operating authority until the time when repairs are complete and the repair crew releases the unit. Repair time delimits the time interval between the operations and maintenance organizations' control.

Repair time begins when operations releases the unit to maintenance.

Repair time ends when operations accepts the repaired unit from maintenance.

Repair time includes any travel time, response time, parts delivery, etc. or any other maintenance/repair related durations within maintenance's accepting and releasing the unit.

NOTE 1: Repair time does *not* include the operations response and disposition time.

NOTE 2: Repair Time only applies for Permanent or Manual Outages which require physical repairs to a transmission unit. The repair end time may coincide closely with the Outage Restoration but always is nested inside the Permanent Restoration.

NOTE 3: Repair time does not include Deferred Restoration (see section 5.6). Repair time may not be continuous, as in some cases of Deferred Restoration, in which instances the Repair Time is the sum of elapsed time of non-continuous repair intervals.

### **5.3. Transfer Point Restoration**

Transfer Point restoration is the date and time when a transfer point is re-energized on a transmission unit having one or more transfer points. It is applicable to Distribution, Production and Interconnection Transfer Points.

#### **5.3.1. Transfer Point Restoration, Transmission Circuit**

Transfer Point restoration for a transmission circuit is the date and time when the *last* transfer point is energized from the transmission system on the transmission circuit.

#### **5.3.2. Transfer Point Restoration, Transmission Circuit Section and Transfer Point**

Transfer Point restoration for a transmission circuit section and transfer point is the date and time when the *each* individual section and transfer point is energized from the transmission system.

NOTE 1: A requirement for the recording of transfer point restoration for a transmission circuit section and transfer point is the ability to record outage data on a circuit section and transfer point basis and have the circuit section(s) and transfer point(s) keyed to the transmission circuit of which it is a part.

NOTE 2: Transfer Point restoration may be partial; the unit may not be at the Available State. In this instance, multiple recordings of Availability State changes are required.

### **5.4. Customer Restoration**

Customer restoration applies to combined transmission and distribution systems where the transmission system and distribution systems are owned by a single owner; thus the number of and service continuity status for distribution customers are known to the transmission owner. Transmission-only systems do not have the customer responsibility or knowledge to track customer restoration.

Customer restoration is the time at which customers are restored to service after an interruption due to a transmission unit(s) unavailability.

NOTE 1: Customer restoration can occur in multiple steps and each step should be recorded.

NOTE 2: Customer restoration is usually simultaneous with transfer point restoration. Situations may occur when a transmission unit is re-energized at a transfer point and there is no limitation or constraint on the transmission unit; however the customer load is not present until a later time. In these cases the customer and load restoration time should be recorded as the time that the transfer point was re-energized and unit capable of carrying load.

#### **5.4.1. Customer Restoration, Transmission Circuit**

Customer restoration for a transmission circuit is the date and time when the *last* customer at the *last* transfer point is energized from the transmission system on the transmission circuit.

#### **5.4.2. Customer Restoration, Transmission Circuit Section and Transfer Point**

Customer restoration for a transmission circuit section and transfer point is the date and time when the *each* individual section and transfer point customers are energized from the transmission system.

NOTE 1: A requirement for the recording of customer restoration for a transmission circuit section and transfer point is the ability to record outage data on a circuit section and transfer point basis and have the circuit section(s) and transfer point(s) keyed to the transmission circuit of which it is a part.

NOTE 2: Customer restoration may be partial; the unit may not be at the Available State. In this instance, multiple recordings of Availability State changes are required.

#### **5.5. Flow Restoration**

Flow refers to ability to transfer power between transmission terminals. Flow restoration is the date and time at which any flow is restored on a transmission unit from one transmission terminal to another.

NOTE 1: Flow Restoration is not used for radial transmission circuits or taps where the (steady-state) power flow is one directional toward the Distribution Transfer Point. The term only has significance between transmission terminals.

NOTE 2: Flow restoration is not charging current or magnetizing current as in the case of energized open-ended configurations (i.e., a minimum of two transmission terminals must have at least one breaker closed at each terminal for Flow Restoration).

NOTE 3: Partial flow capability to a de-rated state is reported by ending the outage record and starting a de-rating state record.

#### **5.6. Deferred Restoration**

Deferred Restoration occurs when a deliberate decision is made to postpone or deliberately delay Permanent Restoration of a transmission unit by the transmission owner with concurrence of the operating authority.

Deferred Restoration is the time interval between a Non-Available State until the time when repairs or return to service are authorized to commence. Deferred Restoration may not be continuous, in which instances the Deferred Restoration is the sum of elapsed time of non-continuous deferment intervals. An example of this occurs when repairs are completed in a non-continuous basis (e.g., repairs only are performed only during daylight hours).

Deferred Restoration decisions are based upon the level of network redundancy, system conditions, cost and availability of labor and material.

Deferred Restoration can skew the unit and system duration statistics while posing inconsequential risk to users or functions of the transmission system. Conversely, these decisions can have real customer impacts in the event of another outage or contingency.

#### **5.7. Permanent Restoration (Restoration to Available State)**

Permanent restoration is the time at which a transmission unit is completely available and functional after a Non-Available State has occurred. All other restoration events have occurred.

The event marks the end of an Outage or Non-Available, Non-Outage State and is used to calculate the total non-available state duration. Most times the full flow restoration and permanent restoration will coincide (e.g., as the final termination is closed for a circuit).

NOTE 1: Cases may exist where a temporary repair restores full functionality at a capability below design rating. Example: A damaged tower was temporarily braced, placed back in service and supports full load but still requires permanent repair of the tower structure. The outage restoration time would mark the re-energized unit in the braced condition, while the

Permanent Restoration would mark the tower's permanent repair. Situations may involve temporary repairs that require a subsequent outage.

## **6. Customer Impact**

Section 5, Restoration to Available State defined the duration of transmission unavailability and critical milestones of restoration, *Customer Impact* quantifies the magnitude of the unavailability impact, both real-time disconnection and actual interruption. Customer Impact is not equivalent to *economic or market impact*.

Customer Impact is the measurable impact to power system users due to Non-Available transmission unit states. This section defines "customer" generically. "Customer" has different meanings to combined transmission and distribution systems versus transmission-only systems. In addition "customer" varies by the type of service received (e.g., high-voltage, bulk service, commercial and industrial, residential, load aggregators and marketers, generators, etc.). This requires that customer impact is defined by number of customers, number of transfer points and load or generation effected.

The applicability of the definitions in this section is represented in Customer Impact Applicability Table 6.1.

### 6.1. Customer Impact Applicability Table

Unit Categorization	Type of System				
	All Systems				Combined T&D Systems Only
Circuits with Transfer Points (TPs)	No. of TPs	TP type	Impact Description	Impact Unit Quantification (Megawatts)	Customer Impact Unit Quantification (# customers)
	(For each connected POR)	Point of Receipt, (POR)	POR Disconnected	Real-time Generation Disconnected	N/A
	(For each connected POR)	POR	POR Interrupted	Actual Generation Interrupted	N/A
	(For each connected POD)	Point of Delivery( POD)	POD Disconnected	Real-time Load Disconnected	Real-time Customers
	(For each connected POD)	POD	POD Interrupted	Actual Load Interrupted	Actual Customers Interrupted
Network Circuits <sup>1</sup>	No. of TPs	TP type	Impact Description	Impact Unit Quantification (Megawatts)	Customer Impact Unit Quantification (# customers)
	Zero <sup>2</sup>	N/A	Partially Disconnected Flow <sup>3</sup>	Real-time Load Disconnected	N/A
			Interrupted Flow <sup>4</sup>	Real-time Load Interrupted	N/A
	Any <sup>5</sup> (AND a Network Circuit)	N/A	Any Flow Impact reported per <b>Network Circuits</b> above		
Either (POD or POR)		Any TP impact reported per <b>Circuits with Transfer Points</b> (above sections)			

Notes, Customer Impact Applicability Table:

1. Circuits with  $\geq 2$  transmission terminals.
2. Network circuits that do not have transfer point taps and do not terminate at transfer points (e.g., internal transmission system circuits with no connected TPs).
3. Remaining flow on unit through termination via closed breaker(s) at multi-breaker termination (e.g., ring-bus or breaker-and-a-half configurations, etc).
4. All breakers for a unit termination at a terminal are open or incapable of permitting flow.
5. Network circuits that also have transfer point taps or terminate at transfer points (e.g., internal transmission circuits that have connected TPs or multi-terminal configuration).

## **6.2. Disconnected Real-time Load**

The Disconnected Real-time Load is the real-time connected load which is disconnected from the unit as a result of unavailability at the start time of the outage. In cases of units that are opened at a single terminal, it is the value, for that unit at the opened terminal's metering in megawatts (MW).

Load may not actually have been interrupted, particularly for transmission units which serve networked distribution systems. Disconnected Real-time Load is reported as the load opened or flow cessation at the unit. In these cases, load service is restored separate and apart from the transmission unit. See Diagram 9.7.

### **6.2.1. Partially Disconnected Flow**

Partially disconnected flow occurs when one breaker in a multi-breaker termination is opened, while the other(s) remain closed. This can occur on network circuits at a transmission terminal termination, or an Interconnection Transfer Point termination where neither Distribution nor Production Transfer Points are directly disconnected. The impact of this is measured as Disconnected Real-time Load, see Diagram 9.7.

## **6.3. Disconnected Real-time Customers**

The Disconnected Real-time Customers are the number of real-time connected customers which are disconnected from the unit as a result of unavailability at the transfer point at the start time of the outage.

Customers may not actually have been interrupted, particularly for transmission units which serve networked distribution systems. In these cases, customer service is restored separate and apart from the transmission unit. See Diagram 9.7

## **6.4. Disconnected Real-time Generation**

The Disconnected Real-time Generation, in megawatts (MW), is the real-time connected generation that is disconnected from the unit as a result of unavailability at the Generation Transfer Point at the start time of the outage. Generation may not have been interrupted in network configurations. See Diagram 9.7.

## **6.5. Actual Load Interrupted**

The amount of actual load interrupted as a result of an outage state. The value is recorded as the actual load interrupted at the start time of the outage.

### **6.5.1. Interrupted Flow**

Interrupted Flow occurs when all breakers of a multi-breaker termination are open at a network circuit termination or on an Interconnection Transfer Point termination where neither Distribution nor Production Transfer Points are directly interrupted.

## **6.6. Actual Customers Interrupted**

The number of connected customers actually interrupted as a result of the outage state at the start time of the outage. This value allows systems to quantify the transmission impacts on distribution customers.

## **6.7. Actual Generation Interrupted**

The amount of actual generation interrupted as a result of the unit unavailability to the Generation Transfer Point at the start of the unavailable state, stated in megawatts (MW).

## **7. Non-Availability Root Cause Description**

Non-available State Root Cause Description is necessary for effective asset management by the transmission owner and assessment of historical performance by customers, operating authorities, regulators and stakeholders.

Root Cause Description is a process of one or more steps. First, operations will code an event with a known or suspected root cause. Second, transmission maintenance will complete a field report of inspection and necessary repairs. If physical damage occurred to a unit, this is usually the final determination of root cause. For more complicated failures (i.e., improper operation of system protection or failure of complex units or components) post-event engineering analysis may be necessary as a third step.

Because systems of root cause description frequently have been already implemented by transmission owners, this document does not propose detailed root cause descriptions. It *proposes* major categories for root cause description and *encourages* transmission owners or operators to add additional levels of detail below the major categories.

## **7.1. Failure Cause Classification**

Failure cause classification identifies whether a transmission unit non-available state resulted from fault, failure or defect condition that caused a unit to be non-available. Failures are broken into major categories, most of which may have responsibility assigned to a separate function within a transmission owner's organization.

### **7.1.1. Terminal Equipment**

Transmission unit outages caused by failures of terminal or substation equipment consisting of breakers, switches, transformers, capacitor banks, busses, etc. *Any* "inside the fence" cause (exclusive of system protection) should be assigned to this category.

### **7.1.2. System Protection**

Transmission unit outages caused by system protection component failure, misoperation, mis-coordination, reverse directionality, incorrect settings or scheme, "over-reaching", communications, etc.

### **7.1.3. Lines**

Transmission circuit outages caused by failed hardware outside of terminals: Structures, conductors, cable, cable hardware, insulators, static wire, foundation, etc.

NOTE: Systems should include wind, lightning and ice conditions which were *within* the design capabilities of the hardware, if wind, lightning or ice values are known.

### **7.1.4. Weather, other than lightning**

Severe weather conditions, beyond the design capabilities of the facilities, resulting in outages, exclusive of lightning.

### **7.1.5. Lightning Only**

Verified or suspected outages resulting from lightning, when magnitude of stroke is verified to exceed design capabilities.

### **7.1.6. Vegetation**

Vegetation and trees directly cause a failure of a transmission unit.

NOTE: The category assumes that "good utility practices" for vegetation management have been in place for the unit in question.

### **7.1.7. External**

Outage causes external to, and *outside the control of the system* (e.g., foreign transmission, underfrequency, instability, customer equipment, generation, distribution through-faults, etc).

### **7.1.8. Human Factors**

This category may include operating and switching errors, contractor or employee errors, poor workmanship, dig-ins, and public damage. Detail cause description should be completed.

### **7.1.9. Other**

None of the above is applicable when using this category. Some of these may include flood, earthquake, solar interference, aircraft, contamination, animals, birds, etc. Detail cause description should be completed.

### **7.1.10. Unknown**

Reasonable and prudent root cause analysis has taken place. All attempts to verify cause were unsuccessful.

## **7.2. Non-Failure, Non-Fault Causes**

Non-available unit state did not result from a failure or fault condition.

### **7.2.1. Operational Outage**

An operational outage is for an individual event(s) which is required to operate the system safely and reliably.

Example 1: A bulk power circuit breaker is opened for system voltage control.

Example 2: A circuit is removed from service to avoid a thermal overload.

Example 3: A producer is removed from economic dispatch; the breaker or disconnect is opened at a production transfer point as the generator stops production.

### **7.2.2. Maintenance and Construction**

These are deferrable outages for the purpose of routine inspection and maintenance or construction on the transmission system. The necessity of the outage is stipulated by maintenance policy of the transmission owner. A defect or condition may be observed that does not impair the ability of the unit to perform all of its functions; however maintenance policy may mandate corrective actions. Maintenance or construction is required on the unit identified for the outage.

NOTE: Distribution under-build, fiber optic or communication facilities are not considered as Maintenance and Construction unless they directly benefit the transmission system.

### **7.2.3. Third Party Request**

It is by request of distribution or generation systems, customers, right-of-way holders, public need or safety, etc.

## **7.3. Major Event Classification**

Major event classification is intended to characterize multiple Non-Available State occurrences, in a short duration of time (e.g., a 24 hour period) which are either overwhelming or beyond the reasonable control of the transmission owner.

Classification as a "major event" assumes that good utility practices are in place. Examples of good practice include restoration crews in an operating region that are either fully deployed or have been moved to safe locations (e.g., hurricane conditions).

An alternative method for major event classification is to calculate average daily number of outages and/or average daily outage duration and set statistical thresholds based on historical averages.

## 7.4. Multiple Contingency States

A multiple contingency state is the occurrence of two or more transmission unit Non-available States which taken together, actually compromise or have the potential to compromise the transmission system as to present an unacceptable risk system to security. A multiple contingency event may be viewed as two events whose sum impact on the system is multiplicative.

As part of post-event analysis, the transmission owner should identify whether concurrent Non-available States resulted in a multiple contingency, or a potential multiple contingency had time of year or configuration been different. This should include both manual (including planned events) and automatic (sustained only) outages.

If a multiple contingency state existed, all Non-available State records should be identified with a common multiple contingency state serial identification.

## 8. Data Management and Reporting Guidelines

This section discusses basic Data Management and Reporting Guidelines. It is not intended to provide a complete design for a Transmission Unit Availability database, data formats and reporting requirements. Rather, these are general guidelines of certain *minimum* attributes, within each Guideline section, which should be present.

A summary of all of the concepts proposed in this document and discussed in this section are illustrated in Diagram 9.9, Data Guidelines and Definitions, Summary Block Diagram.

This section consists of brief descriptions of data guidelines for units, states and causes.

Certain data attributes may be viewed as either basic or advanced requirements for data collection. Recognizing that few, if any systems collect all the data described in this document, data attributes are tagged as either [B] for basic or [A] advanced guidelines. This classification essentially qualifies the maturity of a data collection system.

This section does *not* specifically direct minimum data collection standards. It must be recognized which data elements are collected is system-specific, dependent upon need for management and customer service.

### 8.1. Unit Identification [B]

Transmission units comprise the basic level of transmission availability reporting.

Each transmission unit shall have a concise identifier which is unique to the transmission system and is consistent with other data systems (e.g., system maps, planning, operations, maintenance, etc.). The identifier is supplemented with other information. Supplemental information may include:

- Unit Name (e.g., “From Sub-To Sub” for a transmission circuit or “Name” for a substation or terminal)
- Operating Voltage
- Design Voltage
- Region, District or Operating Company
- Predominant Construction Type (e.g., “Wood H-Frame” or “Steel Lattice” or Underground cable type for a transmission circuit or section)
- In-Service Date
- Length (miles)
- Overhead and Underground Length

### **8.1.1. Unit Hierarchy [A]**

Below basic unit for availability reporting (e.g., a transmission circuit) may be sub-units such as sections, transfer points, taps and terminals.

In order to insure traceability of independent and dependent mode outages of sub-units, they must be indexed to the next-highest unit. Data recorded for sub-units should be similar to that in section 8.1.

Example 1: A transmission circuit section is indexed to the transmission circuit of which it is a part.

Example 2: The transmission circuit section in Example 1 contains a Delivery Transfer Point. The Delivery Transfer Point is indexed to the transmission circuit and section of which it is a part.

### **8.1.2. Unit Serialization and Traceability [A]**

Physical characteristics of transmission units may change over time. Examples include changes in operating voltage, addition of length, segmenting into two or more pieces, addition of taps or transfer points or changing configuration (e.g., a section is transferred to another circuit).

Because some or all of the physical exposure often remains the same, it is relevant to have a mechanism to retain the state history with the unit. For instance, knowing that a given transmission circuit section has had repeated lightning outages is relevant even if the circuit section is rebuilt, extended or made part of a different circuit.

Serialization should contain the “old” unit identification, the “new” unit identification, description and the date of the change.

## **8.2. Defect, Failure and Fault Identification [A]**

Each unique defect, fault or failure will be identified with the corresponding state record. The identification of defects, faults or failures will be consistent with descriptions contained in section 3. For faults, the state record should identify which phase(s) were involved in a fault.

## **8.3. Dependency and Commonality [A]**

The dependency and commonality of state records will identify each state record consistent with descriptions contained in section 4.

For identifying dependent mode events, it is necessary to have a unique “event identification” for each independent event.

Dependent mode outage state record(s) must contain the unique “event identification” of the initiating independent event, plus a unique serial or incident identification.

For common-mode events, the “event identification” is identical, but there must be another data element to identify commonality (e.g., a binary flag).

## **8.4. State Identification**

The available state does not have to be an independently recorded item and may be inferred from either the closure of a non-available state record or the absence of any state records for a given unit. Data is recorded for non-available states.

### **8.4.1. Units Recorded in State Changes**

There are multiple levels of detail for reporting of available states for transmission units.

#### **8.4.1.1. Basic Reporting [B]**

Each transmission circuit (section 1.4.3) has outage state changes recorded.

#### 8.4.1.2. Advanced Reporting [A]

Transmission circuits and sub-units in sections 1.4.3.2 through 1.4.3.4 have all state changes recorded.

#### 8.4.2. Recording for Any State Change [B]

Each state change is delimited with an initiation date and time and an ending date and time value. The type of state change should be consistently identified (e.g., outage, scheduled outage, etc).

#### 8.4.3. Use of Date and Time Formats [B]

The recording of state changes must be in a date and time format. They are a *combined* date and time value, representing the elapsed seconds from a fixed starting point and have a form: ddmonyy:hh:mm:ss and are common to all database software products. Using individual integer fields for these values is unacceptable because it makes use of date/time arithmetic difficult.

Decimal seconds are desirable to correlate state changes with archived EMS or lightning stroke data [A].

#### 8.4.4. Non-Outage States [A]

Non-outage states are recorded consistent with section 5.2.1. Records should record type of condition (de-ratings, temporary repair conditions, loss of operational function, etc) and the unit, sub-unit and/or component identification.

#### 8.4.5. Outage States

Outage states should be recorded consistent with the definitions contained in section 5.2.2. The following table indicates whether the attribute is considered as [B] basic or [A] advanced.

Section	Type of Outage	[B] Basic or [A] Advanced
4.2.2.1.	Partial Outage	[A]
4.2.2.2.	Full Outage	[B]
4.2.2.3.	Manual Outage	[B]
4.2.2.3.1.	Deferrable Outage	[A]
4.2.2.3.1.1.	Planned Outage (adequate clearance time)	[A]
4.2.2.3.1.2.	Planned Outage (insufficient clearance time)	[A]
4.2.2.3.2.	Emergency Outage	[B]
4.2.2.4.	Automatic Outage	[B]
4.2.2.4.1.	Transient Outage	[B]
4.2.2.4.2.	Sustained Outage	[B]
4.2.2.4.2.1.	Temporary Outage	[B]
4.2.2.4.2.2.	Permanent Outage	[B]

### 8.5. Restoration to Available State

The Restoration to Available State should be recorded consistent with the definitions contained in section 6. The following table indicates whether the attribute is considered as [B] basic or [A] advanced.

Section	Restoration	[B] Basic or [A] Advanced
5.1.	Outage Restoration	[B]
5.2.	Repair Time	[A]
5.3.	Transfer Point Restoration	[B]
5.3.1.	Transfer Point Restoration, Transmission Circuit	[B]
5.3.2.	Transfer Point Restoration, Transmission Circuit Section	[A]
5.4.	Customer Restoration	[A]
5.5.	Flow Restoration	[B]
5.6.	Deferred Restoration	[A]
5.7.	Permanent Restoration	[A]

### 8.6. Customer Impact

Customer impact data should be collected in accordance with section 6. All customer impact report is **[A]** Advanced.

NOTE: Advanced systems report customer impacts at each stage of multiple restoration steps.

### 8.7. Non-Availability Root Cause Description

Non-Availability Root Cause Description data should be collected in accordance with section 7. Depending on level of detail, the cause description may be either **[B]** basic or **[A]** advanced.

Section	Root Cause Category	[B] Basic or [A] Advanced
7.1.1.	Terminal Equipment	[B]
7.1.2.	System Protection	[B]
7.1.3.	Lines	[B]
7.1.4.	Weather, other than lightning	[B]
7.1.5.	Lightning Only	[A]
7.1.6.	Vegetation	[B]
7.1.7.	External	[B]
7.1.8.	Human Factors	[B]
7.1.9.	Other	[B]
7.1.10.	Unknown	[B]
7.2.	Non-Failure Causes	[A]

## **9. Diagrams**

### **9.1. System Diagram and Transfer Points**



# System Diagram

## Transfer Points

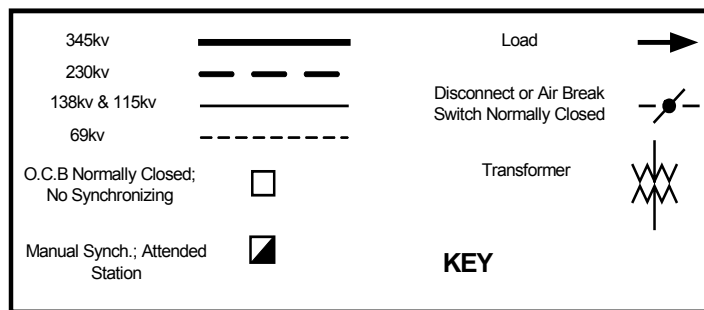
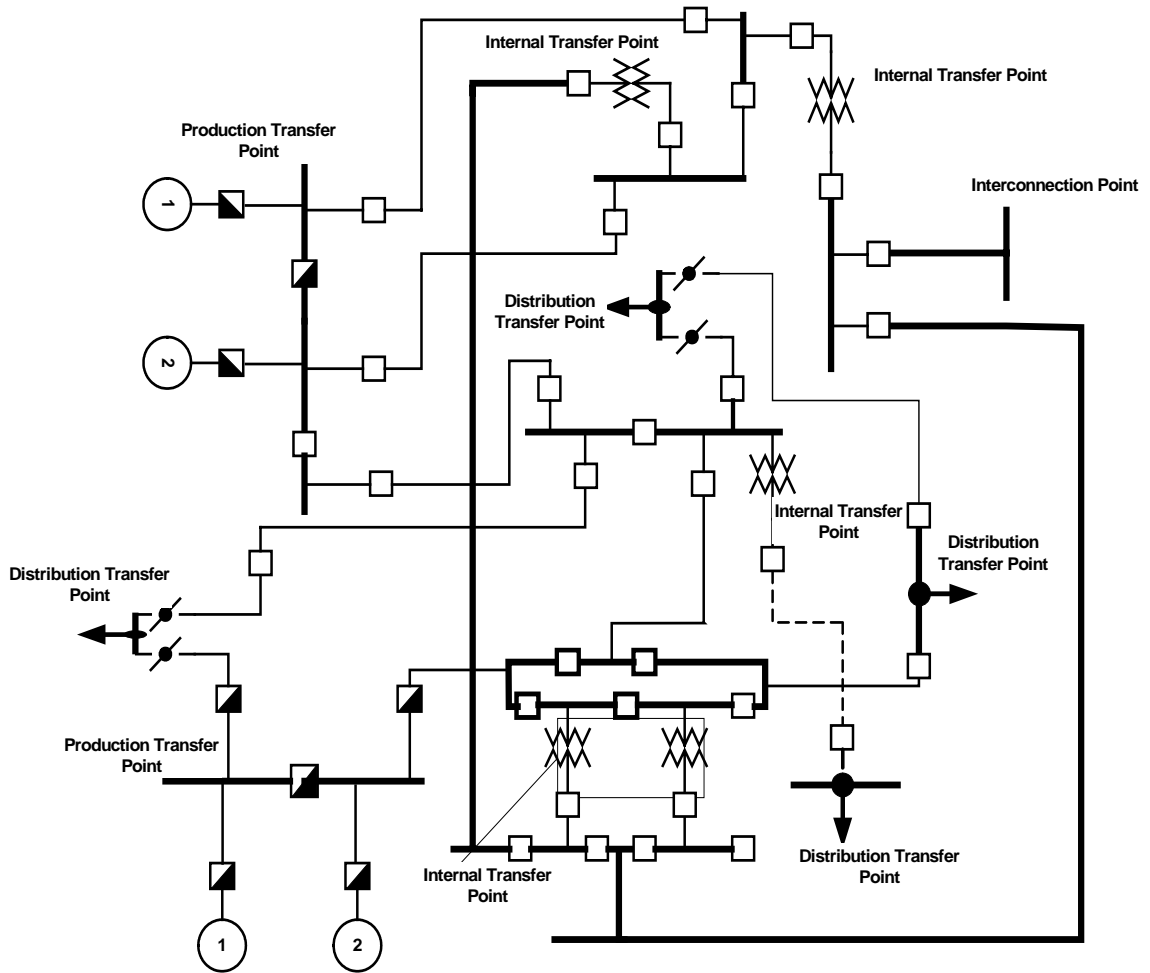

## 9.2. Units and Sub-Units

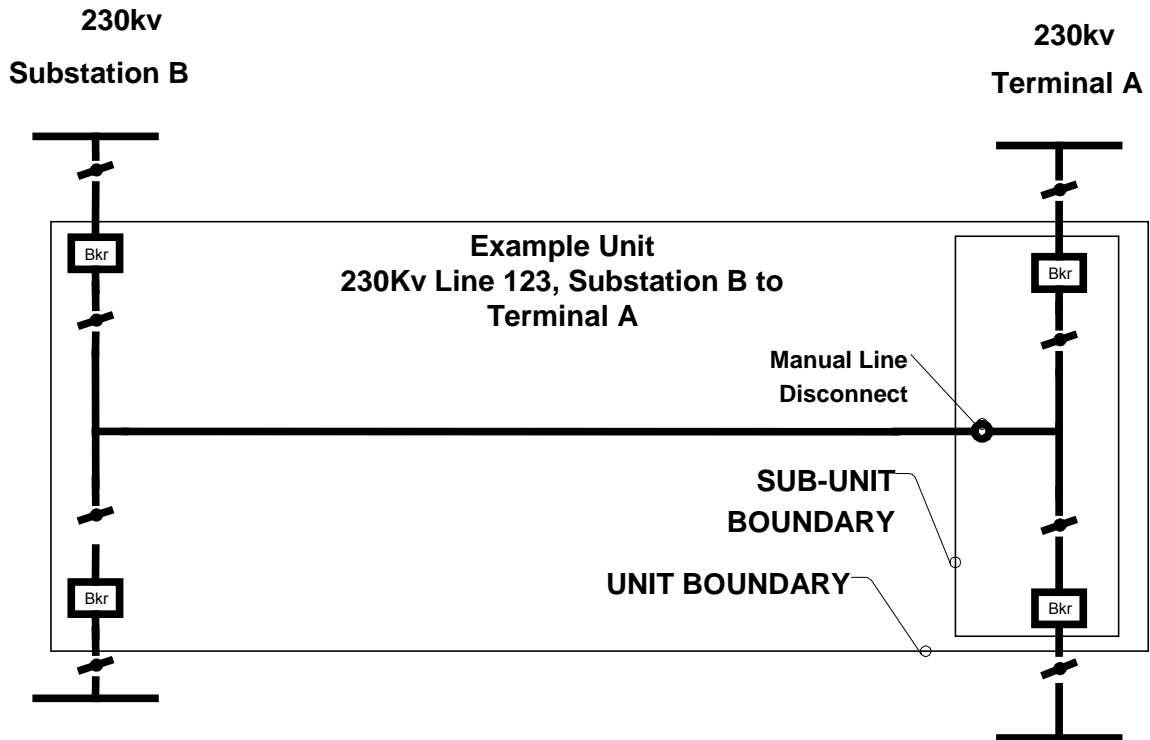

### Example Unit Boundary Discussion:

1. Line is a unit with boundaries comprised of two breakers at each end. Faults within the four breaker boundary are designed to be cleared by the line's system protection. These four breakers comprise the unit's protected zone.
2. Terminal A, Bus section is a Sub-Unit. The manual line disconnect is by design incapable of fault clearing for bus faults.
3. Substation B was configured without a line disconnect for purposes of illustration, which is not typical.

### 9.3. Station Unit Example

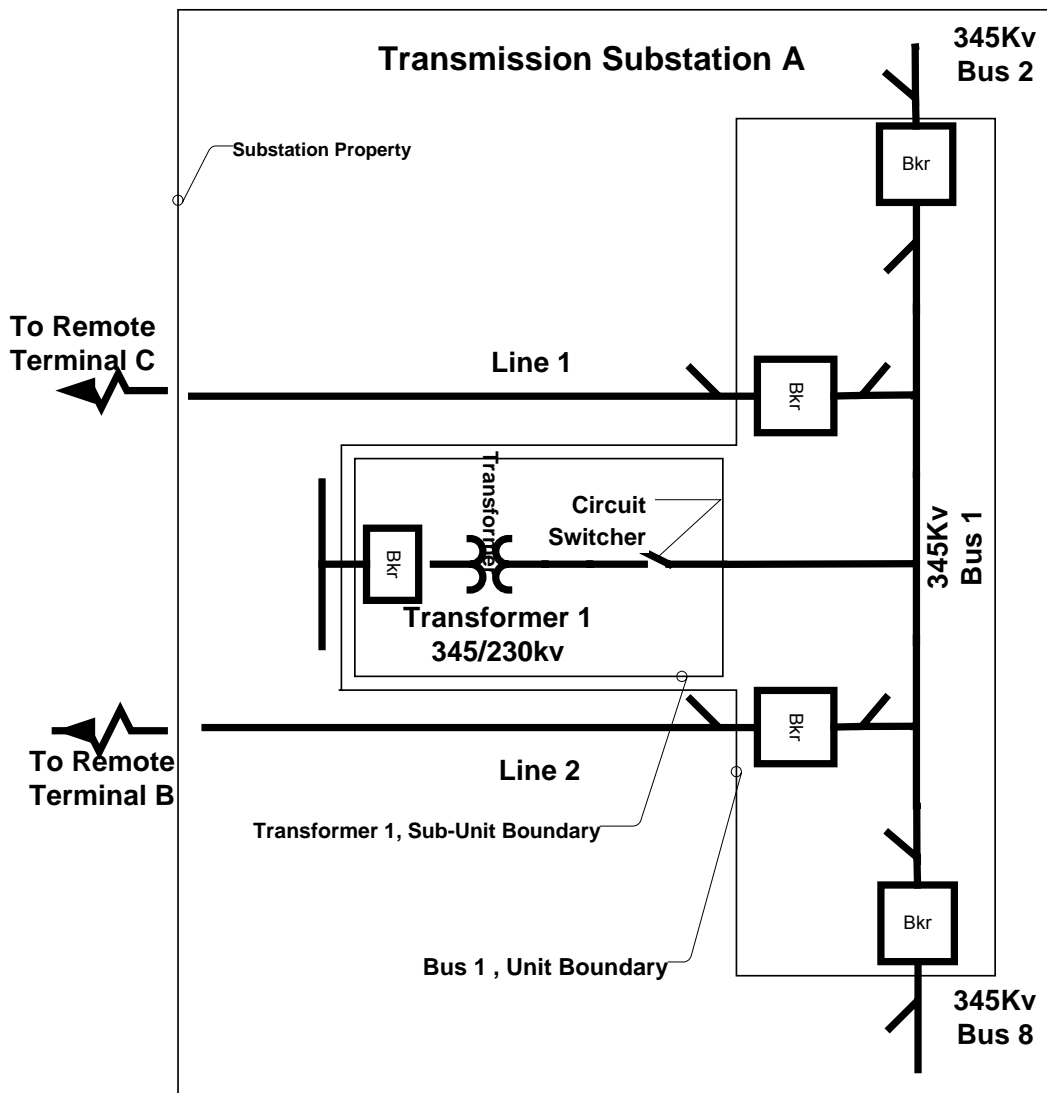

#### **Station Bus Unit Example**

1. Bus Unit bounded by: Bus tie (BT) 1-8, BT1-2, Line 1 CB, Line 2 CB, and Tx 1 CB. Transformer 1's circuit switcher is incapable of fault clearing faults. These circuit breakers are tripped upon Bus 1 system protection initiation.
2. Line 1 CB and Line 2 CB are common terminations for Bus 1 and Line 1 and Line 2 respectively.
3. Transformer 1's unit boundaries are identical to Bus 1's. The transformer differential protection also initiates the trip of circuit switcher in parallel with the unit's protected zone. The circuit switcher is effective only for limited fault scenarios such as low side faults or close in thru-faults. Thus Transformer 1 sub-unit is a constituent of these two units.

#### 9.4. Units with Normally Open Breaker configurations

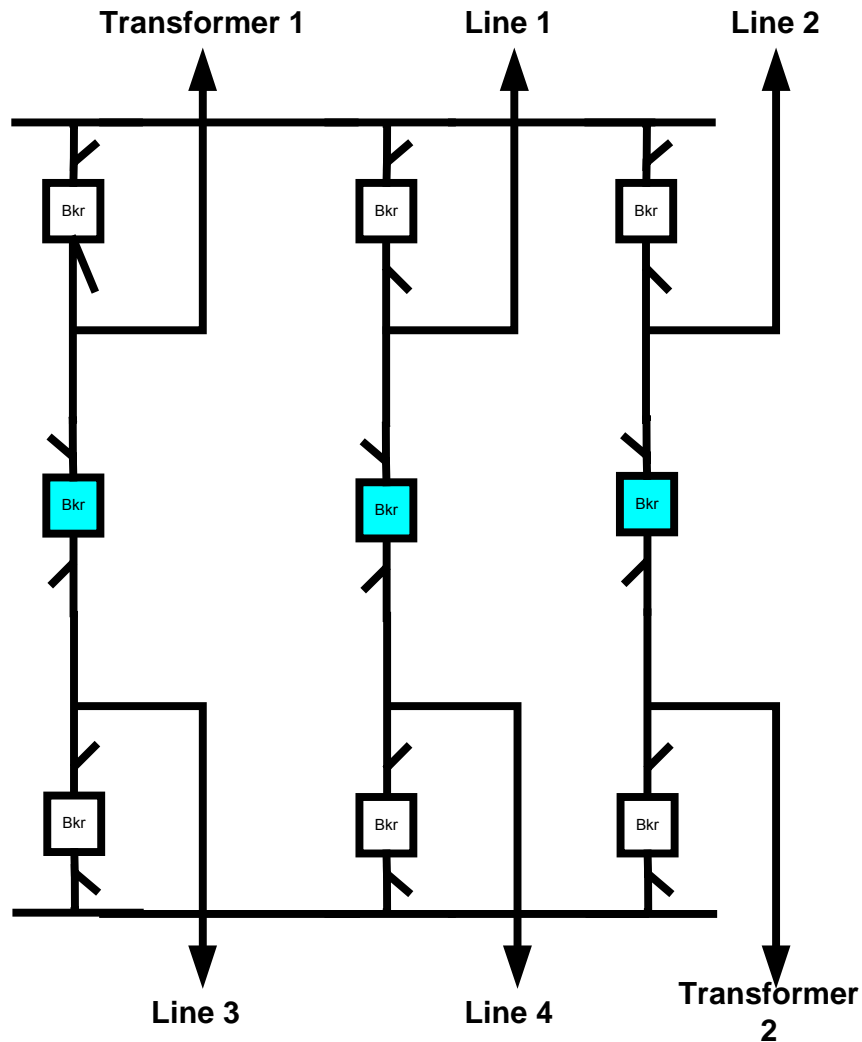

##### **Units with Normally Open Breaker Configurations**

1. Shaded breakers are operated Normally Open. All six units terminate similarly and have two breakers that form the termination at this station. The Normally Open breakers are common equipment to each adjoining unit, top and bottom, respectively.
2. Protected zones for each unit would initiate top and bottom breakers.
3. Normally Open configurations are often dictated by design considerations for system security and adequacy, i.e. to improve system transient stability, or to limit fault duty on the system.
4. Redundant configurations, such as this “breaker and one half” scheme offer increased operational flexibility.

**NOTE: The OPEN condition of a Normally Open breaker does not constitute a state of Unavailability.**

## 9.5. Transmission Circuit Unit Examples

### Two Terminal Transmission Line 1

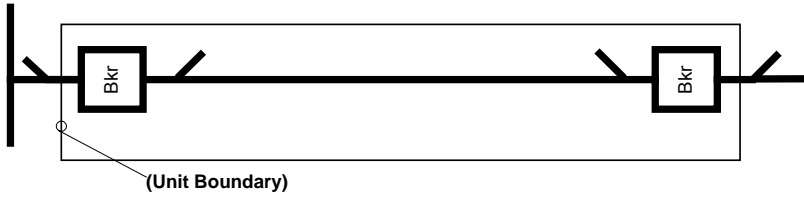

### Tapped, Two Terminal Transmission Line 2

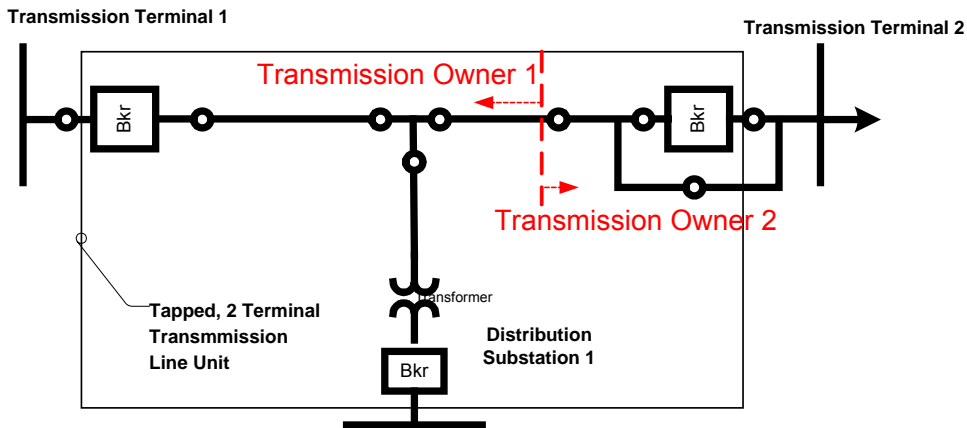

### Tapped, Three Terminal Transmission Line 3

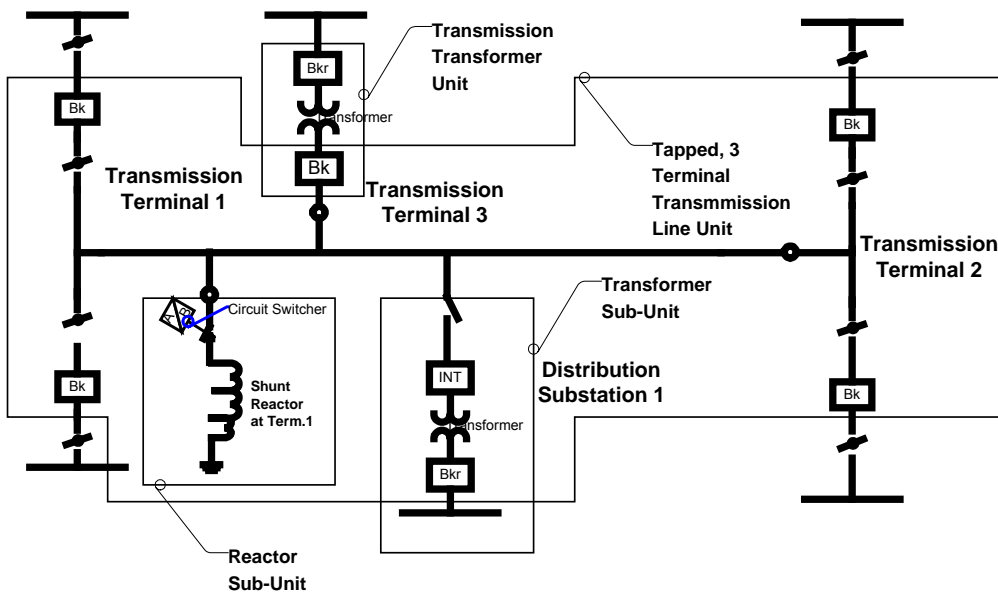

## 9.6. Transmission Circuit Segment Examples

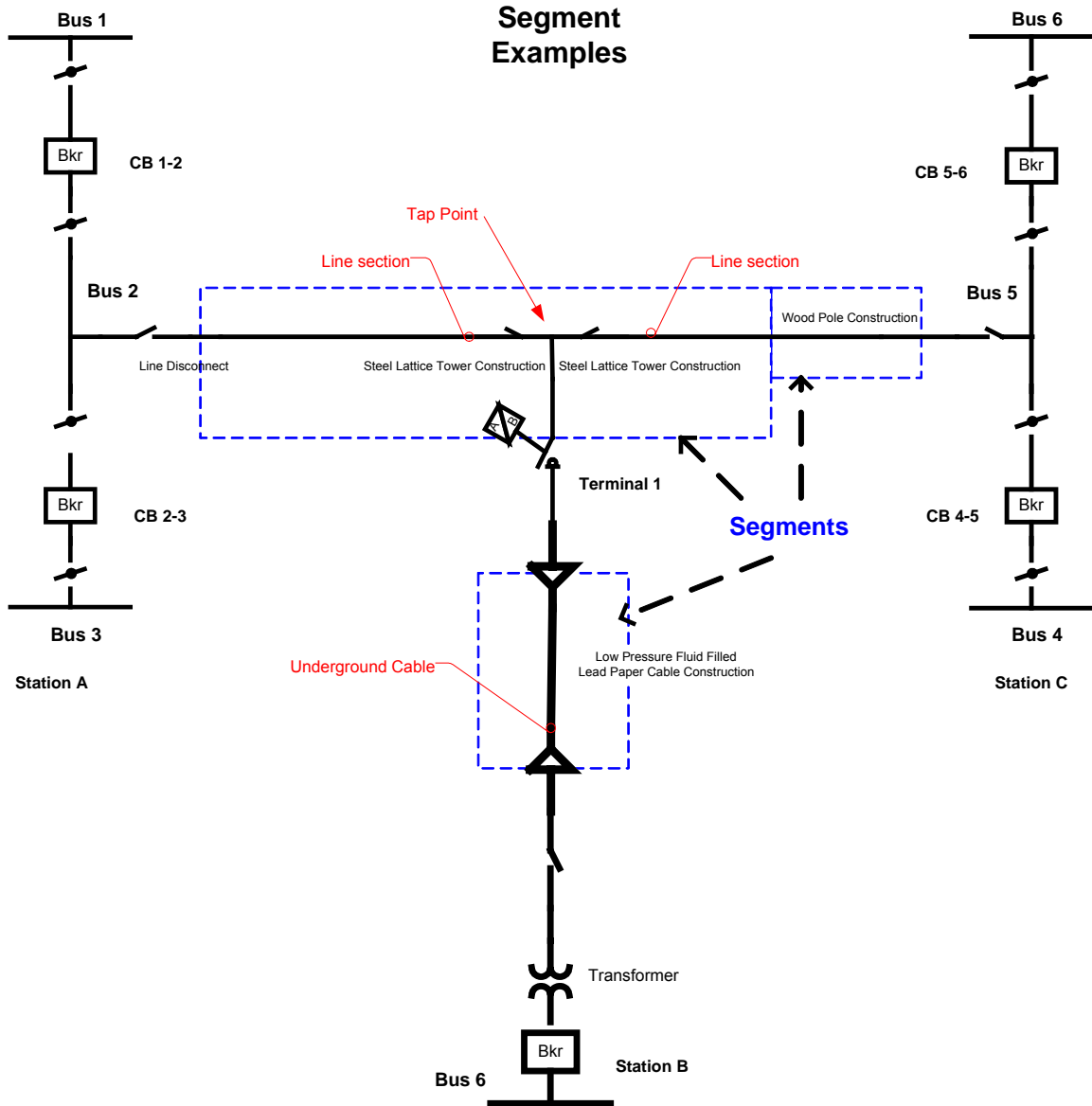

## 9.7. Customer Impact Examples

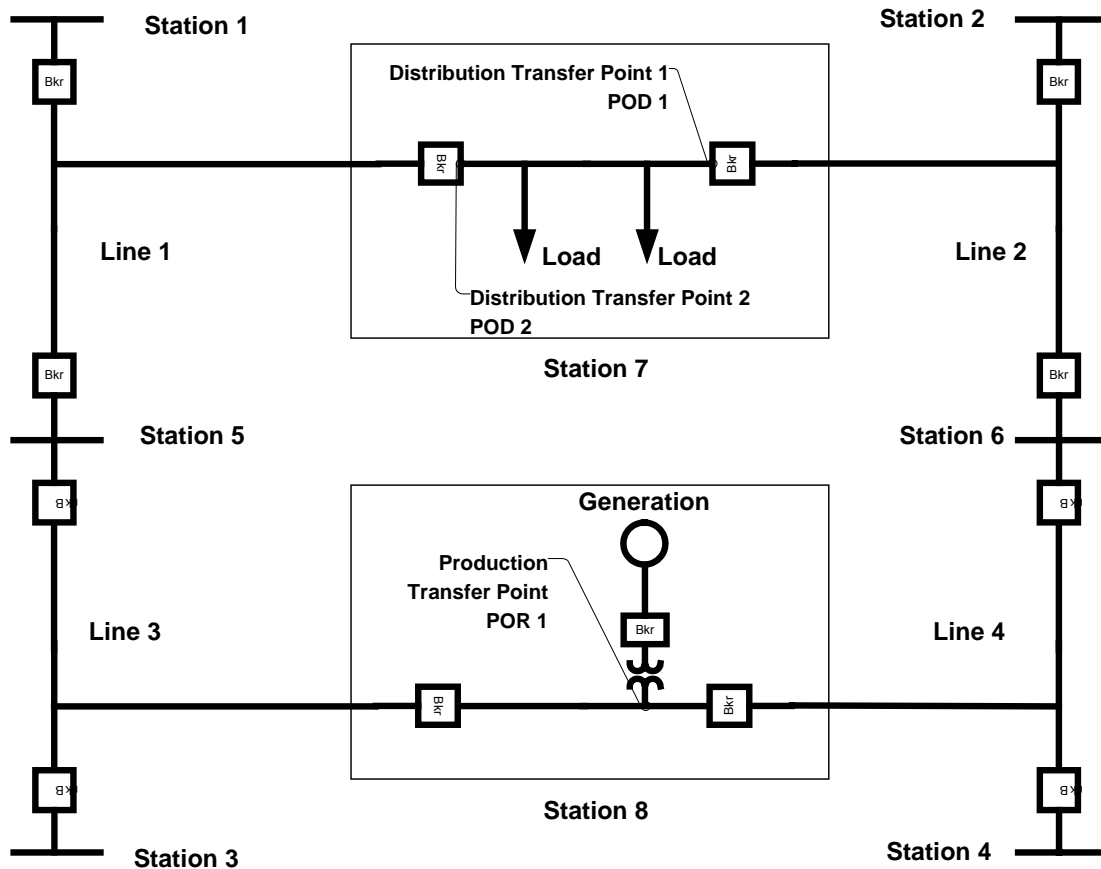

### **Customer Impact Examples**

1. Condition: POR 1's generation is in active production.

If either breaker at Station 8 is opened, i.e. Planned outage for Maintenance, on either Line 3, or Line 4, then POR 1 is DISCONNECTED from units Line 3 or Line 4 respectively, due to the Unavailability of the line opened.

2. If during the above Planned Maintenance outage conditions, a fault occurs on the remaining line to Station 8 tripping the other breaker, then the POR 1 is INTERRUPTED, due to the Unavailability of the faulted line.

3. Conditions: (a) BOTH breakers at Station 8 are closed with POR 1's generation in active production. (b) Line 4's breaker at Station 6 is opened again for Planned Maintenance.

There is PARTIALLY DISCONNECTED FLOW at Station 6 due to the Partial Unavailability of Line 4. There is no impact at POR1 (no disconnection or interruption to the Production Transfer Point).

4. Similar examples apply to Distribution Transfer Points. Station 7 is shown with two POD's due to ownership of equipment at this location. The facilities at this station are customer owned with the exception of the two line circuit breakers, Line 1 and Line 2 CB's. POD's are designated at the bus side disconnects for each line circuit breaker.

5. System Map representation, disconnects not shown. Bulk customer at Station 7.

### 9.8. Outage Restoration Diagram

Unavailability start, (Permanent Outage)

**Outage Restoration Diagram**

Unavailability end, (Permanent Restoration)

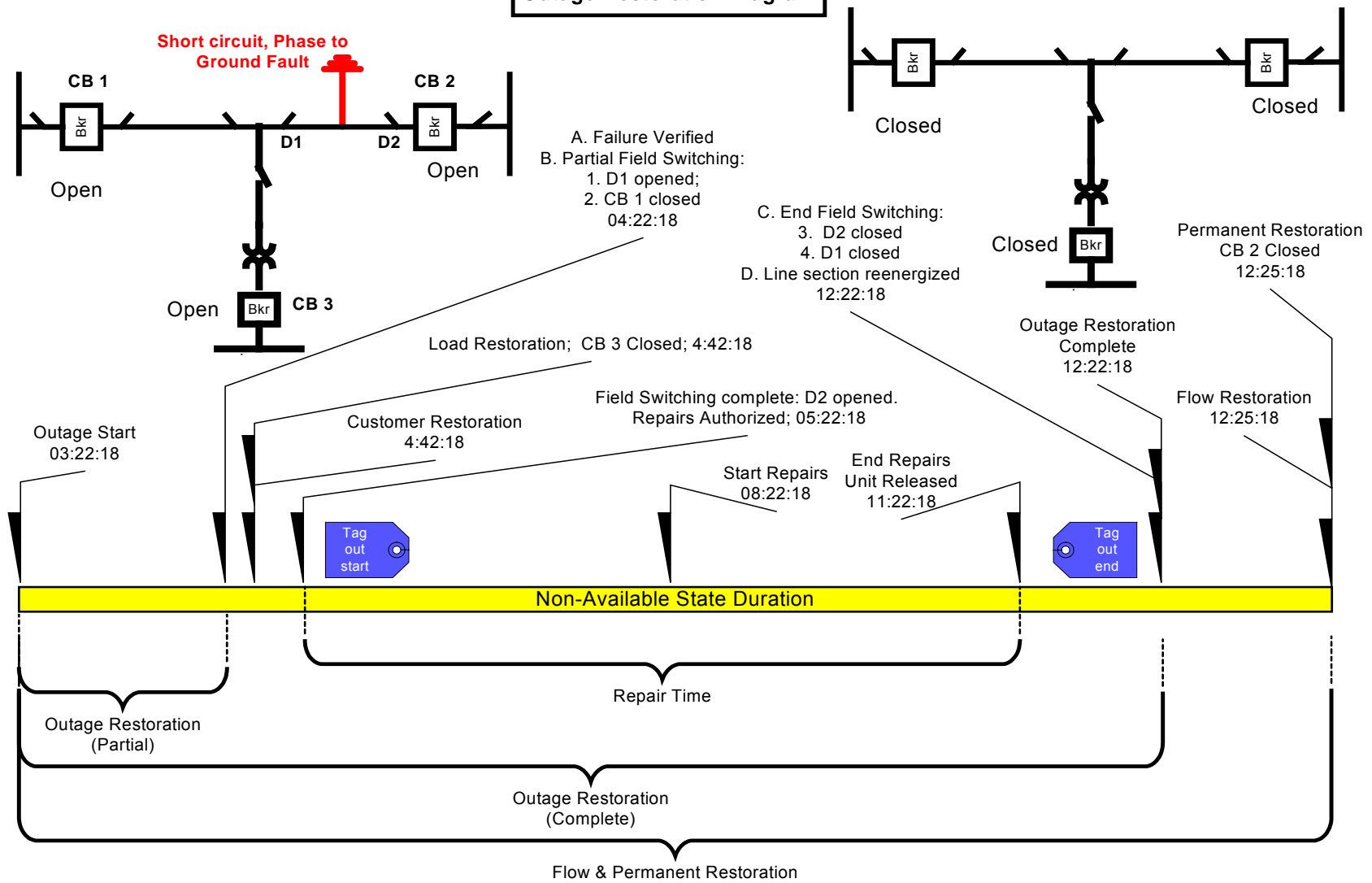

**Tapped, Two Terminal Transmission Circuit Example**

9.9. Data Guidelines and Definitions, Summary Block Diagram

**Transmission Unit Availability Data Guidelines and Definitions  
Summary Block Diagram**

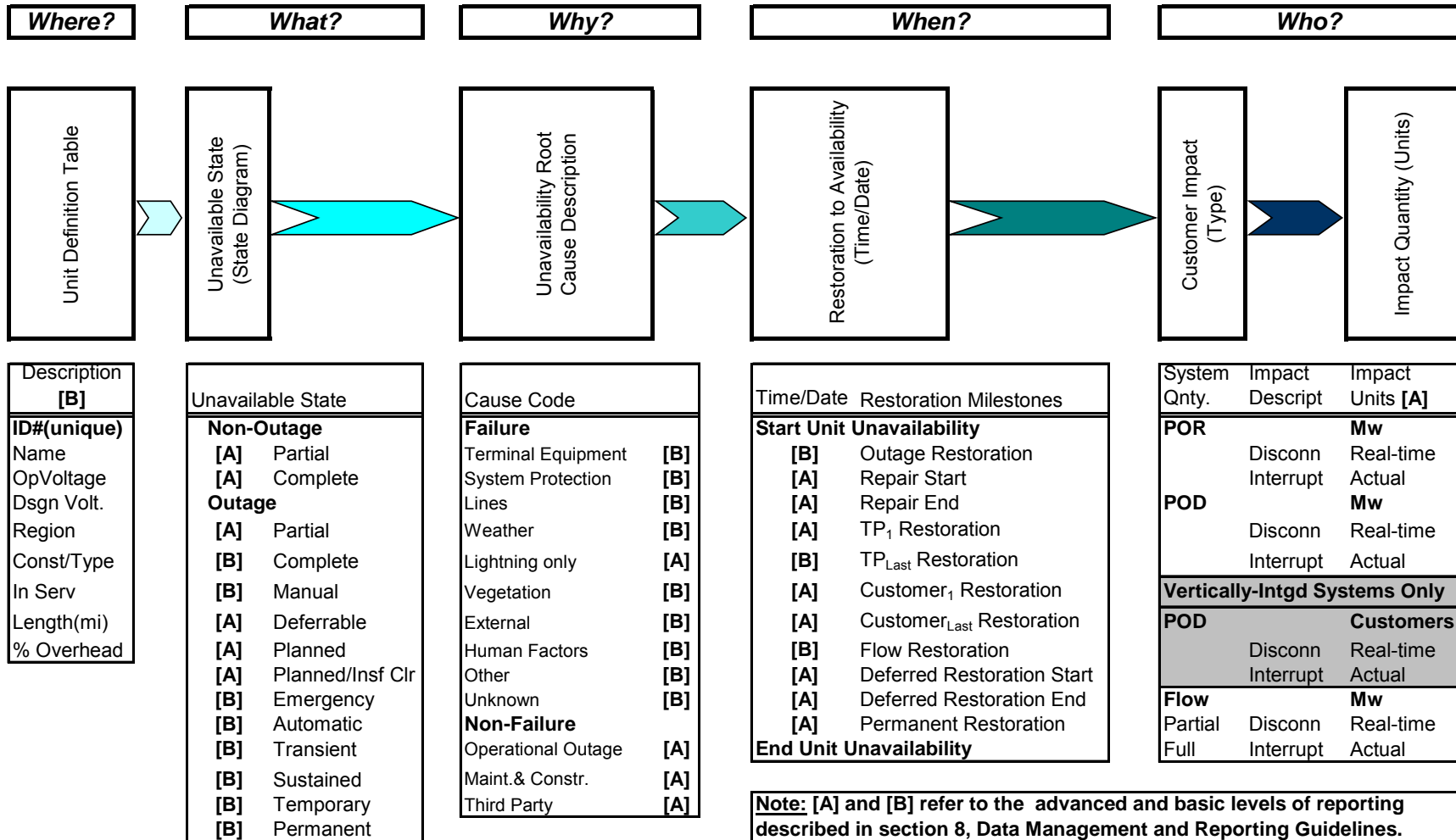

## 10. Appendix

### 10.1. Endnotes

- 
- 1 Power System Reliability Analysis Application Guide, CIGRE WG 03 of SC 38 (Power system analysis and techniques) – 1987, Lesley Kelley-Regnier, Editor, Appendix III Terminology, Section 1-02
  - 2 Ibid., Section 1-01
  - 3 FERC Docket Nos. RM95-8-000 and RM94-7-001, page 402
  - 4 Power System Reliability Analysis Application Guide, CIGRE WG 03 of SC 38 (Power system analysis and techniques) – 1987, Lesley Kelley-Regnier, Editor, Appendix III Terminology, Section 1-04
  - 5 Ibid., Section 1-12
  - 6 Ibid.
  - 7 Ibid., Section 1-23
  - 8 Ibid., Section 1-22
  - 9 Ibid., Section 1-19
  - 10 Ibid., Section 1-18
  - 11 Ibid., Section 1-17
  - 12 Ibid., Section 1-20
  - 13 Ibid., Section 1-21
  - 14 Ibid., Section 4-04
  - 15 Ibid, Section 4-05
  - 16 Ibid, Section 4-06
  - 17 Ibid., Section 4-07
  - 18 Adapted from Power System Reliability Analysis Application Guide, CIGRE WG 03 of SC 38 (Power system analysis and techniques) – 1987, Lesley Kelley-Regnier, Editor, Chapter 6, Section 6.3, page 97
  - 19 Ibid., Section 6.4, page 97